

120A Forward/Reverse Brushless DC Motor Controller with Hall and Encoder Inputs, USB and CAN



Roboteq's MBL16xx is a high-current controller for hall-sensor equipped Brushless DC motors. The controller uses the position information from the sensors to sequence power on the motor's 3 windings in order to generate smooth continuous rotation. The controller also uses the Hall sensor or encoder input information to compute speed and measure travelled distance inside a 32-bit counter. The motor may be operated in open or closed loop speed mode.

The MBL16xx accepts commands received from an RC radio, Analog Joystick, wireless modem, or microcomputer. Using CAN bus, up to 127 controllers can be networked on a single twisted pair. Numerous safety features are incorporated into the controller to ensure reliable and safe operation.

The controller's operation can be extensively automated and customized using Basic Language scripts. The controller can be configured, monitored and tuned in realtime using a Roboteq's free PC utility. The controller can also be reprogrammed in the field with the latest features by downloading new operating software from Roboteq.

Applications

- Small Electric Vehicles, Electric Bikes
- Electric Boats
- Terrestrial and Underwater Robotic Vehicles
- Automatic Guided Vehicles
- Police and Military Robots
- Hazardous Material Handling Robots
- Telepresence Systems
- Animatronics
- Industrial Controls
- Hydraulic Pumps control

Key Features

- RS232, 0-5V Analog, or Pulse (RC radio) command modes
- Auto switch between RS232, Analog, or Pulse based on user-defined priority
- CAN bus interface at up to 1Mbit/s
- Built-in 3-phase high-power drivers for one brushless DC motor at up to 120A
- Trapezoidal switching based on Hall Sensor position information
- Full forward & reverse motor control. Four quadrant operation. Supports regeneration
- Operates from a single power source
- Programmable current limit up to 120A for protecting controller, motor, wiring and battery.
- Connector for Hall Sensors
- Accurate speed and Odometry measurement using Hall Sensor or encoder data
- Quadrature encoder input with 32-bit counter
- Up to 4 Analog Inputs for use as command and/or feedback
- Up to 5 Pulse Length, Duty Cycle or Frequency Inputs for use as command and/or feedback
- Up to 6 Digital Inputs for use as Deadman Switch, Limit Switch, Emergency stop or user inputs
- Two general purpose 40V, 1.5A output for brake release or accessories
- Custom scripting in Basic language. Execution speed 50000 lines per second
- Selectable min, max, center and deadband in Pulse and Analog modes
- Selectable exponentiation factors for each command inputs

- Trigger action if Analog, Pulse, Encoder or Hall counter capture are outside user selectable range (soft limit switches)
- Open loop or closed loop speed control operation
- Closed loop position control with encoder, analog or pulse/frequency feedback
- PID control loop
- Support for CANopen and two simplified CAN protocols
- Configurable Data Logging of operating parameters on RS232 Output for telemetry or analysis
- Built-in Battery Voltage and Temperature sensors
- Optional 12V backup power input for powering safely the controller if the main motor batteries are discharged
- Power Control wire for turning On or Off the controller from external microcomputer or switch
- No consumption by output stage when motors stopped
- Regulated 5V output for powering RC radio, RF Modem or microcomputer
- Separate Programmable acceleration and deceleration for each motor
- Ultra-efficient 1.5 mOhm ON resistance MOSFETs
- Auto stop if no motion is detected
- Stall detection and selectable triggered action if Amps is outside user-selected range
- Short circuit protection with selectable sensitivity levels
- Overvoltage and Undervoltage protection
- Watchdog for automatic motor shutdown in case of command loss
- Overtemperature protection
- Diagnostic LED
- Efficient heat sinking using conduction bottom plate. Operates without a fan in most applications
- Power wiring via FASTON terminals
- 5.50" (140mm) L, 4.45" W (113mm), 0.78" (20mm) H
- -40o to +85o C operating environment
- 3.5oz (100g)
- Easy configuration, tuning and monitoring using provided PC utility
- Field upgradeable software for installing latest features via the internet

Orderable Product References

Reference	Number of Channels	Amps/Channel	Volts	CAN	USB	Case
MBL1630C	1	120	30	No	Yes	Yes
MBL1650C	1	120	50	No	Yes	Yes
MBL1630CN	1	120	30	Yes	No	Yes
MBL1650CN	1	120	50	Yes	No	Yes

Important Safety Disclaimer

Dangerous uncontrolled motor runaway condition can occur for a number of reasons, including, but not limited to: command or feedback wiring failure, configuration error, faulty firmware, errors in user script or user program, or controller hardware failure.

The user must assume that such failures can occur and must make his/her system safe in all conditions. Roboteq will not be liable in case of damage or injury as a result of product misuse or failure.

Power Wires Identifications and Connection

Power connections are made through FASTON tabs. For more power handling the Supply and Motor tabs are doubled and should be connected in parallel.

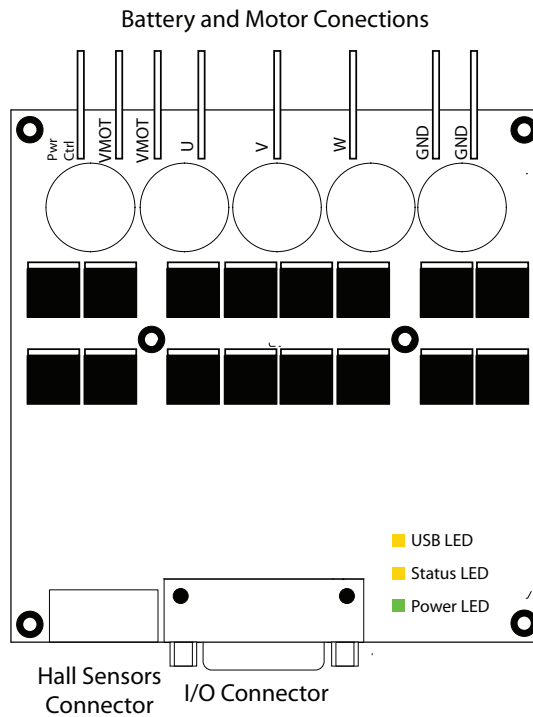

FIGURE 8. Controller Layout

The diagram below shows how to wire the controller and how to turn power On and Off.

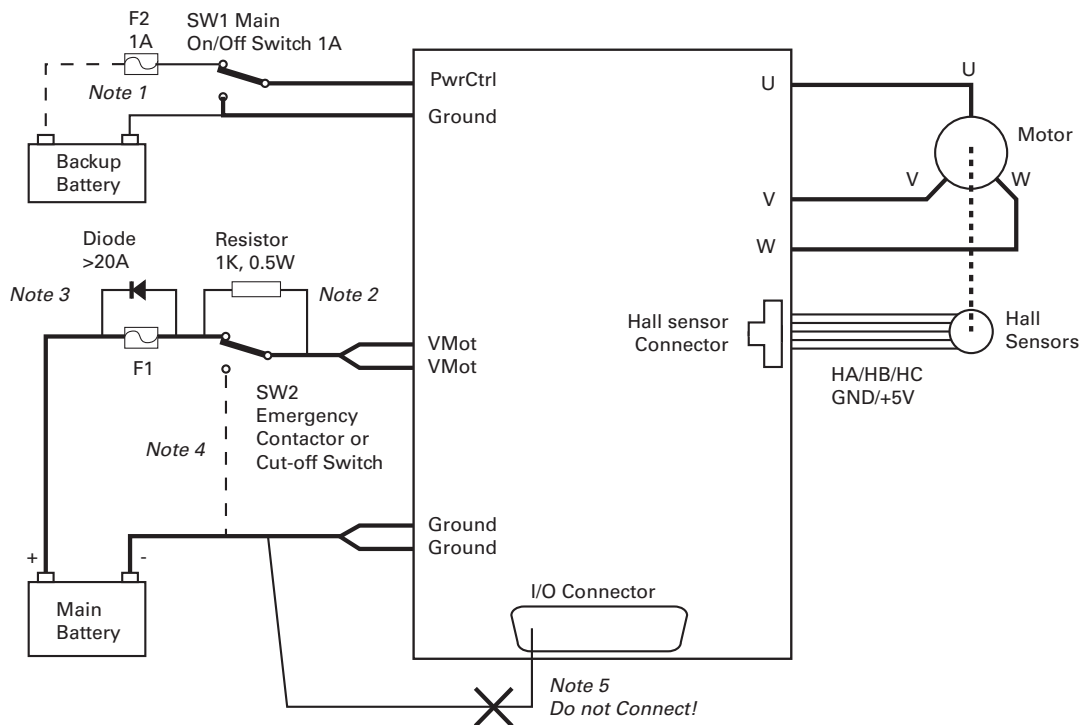

FIGURE 9. Powering the controller. Thick lines identify **MANDATORY** connections

Important Warning

Carefully follow the wiring instructions provided in the Power Connection section of the User Manual. The information on this datasheet is only a summary.

Mandatory Connections

It is imperative that the controller is connected as shown in the above diagram in order to ensure a safe and trouble-free operation. All connections shown as thick black lines are mandatory. The controller must be powered On/Off using switch SW1 on the Power Control tab. Use a suitable high-current fuse F1 as a safety measure to prevent damage to the wiring in case of major controller malfunction.

Emergency Switch or Contactor

The battery must be connected in permanence to the controller's VMot tab via a high-power emergency switch or contactor SW2 as additional safety measure. The user must be able to deactivate the switch or contactor at any time, independently of the controller state.

Precautions and Optional Connections

Note 1: Backup battery to ensure motor operation with weak or discharged batteries, connect a second battery to the Power Control wire/terminal via the SW1 switch.

Note 2: Use precharge 1K, 0.5W Resistor to prevent switch arcing.

Note 3: Insert a high-current diode to ensure a return path to the battery during regeneration in case the fuse is blown.

Note 4: Optionally ground the VMot input when the controller is Off if there is any concern that the motors could be made to spin and generate voltage in excess of 30V (MBL1630) or 50V (MBL1650).

Note 5: Beware not to create a path from the ground pins on the I/O connector and the battery minus terminal.

Use of Safety Contactor for Critical Applications

An external safety contactor must be used in any application where damage to property or injury to person can occur because of uncontrolled motor operation resulting from failure in the controller's power output stage.

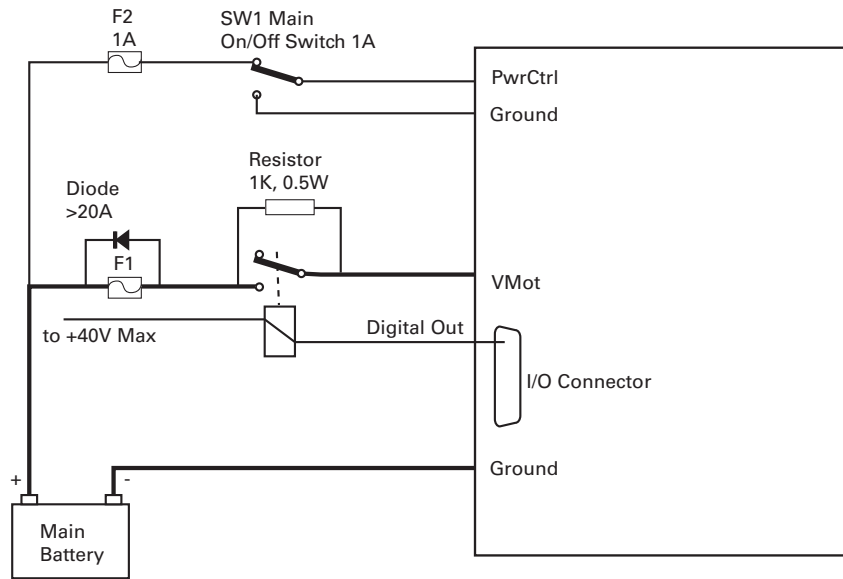

FIGURE 10. Contactor wiring diagram

The contactor coil must be connected to a digital output configured to activate when “No MOSFET Failure.” The controller will automatically deactivate the coil if the output is expected to be off and battery current of 1A or more is measured for more than 0.5s. This circuit will not protect against other sources of failure such as those described in the “Important Safety Disclaimer” on page 3.

Controller Mounting

During motor operation, the controller will generate heat that must be evacuated. The published amps rating can only be fully achieved if adequate cooling is provided. Mount the controller so that the bottom plate makes contact with a metallic surface (chassis, cabinet) to conduct the heat.

Hall Sensors Connection

The Hall sensor connector is a 6-pin Molex Microfit 3.0, model 43645. Pin assignment is in the table below.

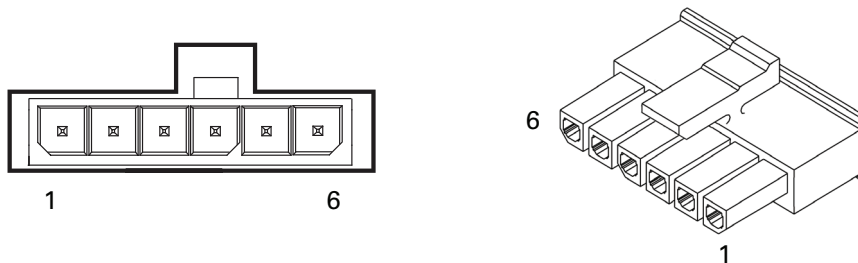

FIGURE 11. Hall Sensors connector

TABLE 4.

Pin Number	1	2	3	4	5	6
Signal	5V	Reserved	Hall C	Hall B	Hall A	Ground

Hall Sensor vs Motor Output sequencing

The controller requires the Hall sensors inside the motor to be 120 degrees apart. The controller's 3-phase bridge will activate each of the motor winding according to the sequence shown in the figure below.

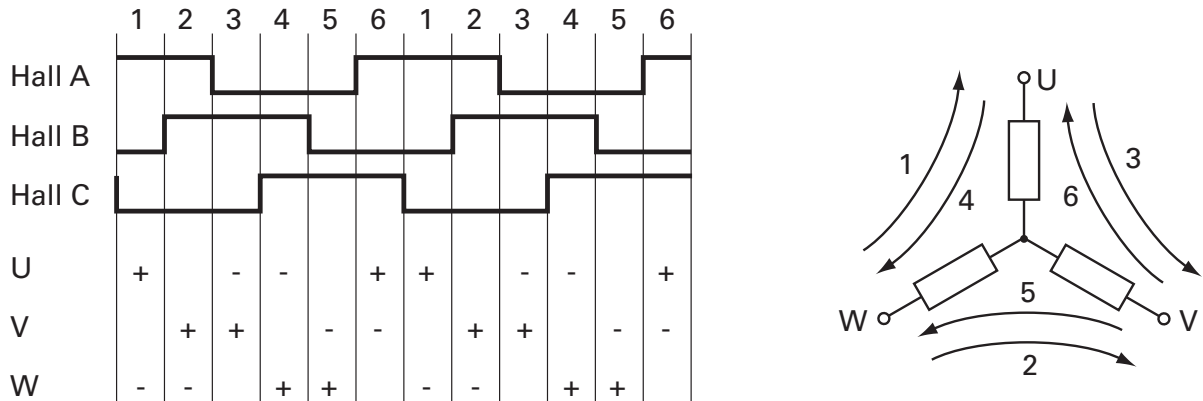

FIGURE 12. Hall Sensors sequence

Commands and I/O Connections

Connection to RC Radio, Microcomputer, Joystick and other low current sensors and actuators is done via the 15-pin connector located in front of the controller. The functions of many pins vary depending on controller model and user configuration. Pin assignment is found in the table below.

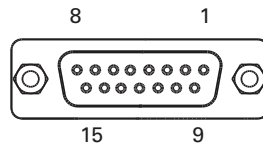

FIGURE 13. Connector pin locations

TABLE 5.

Connector Pin	Power	Dout	Com	RC	Ana	Dinput	Enc	Default Config
1		DOUT1						Brake
9		DOUT2						Contactur
2			TxOut					RS232Tx
10				RC5 (1)	ANA5 (1)(2)	DIN5 (1)	ENCA (3)	Encoder (3)
3			RxIn					RS232Rx
11				RC4	ANA4	DIN4		AnaCmd (4)
4				RC1	ANA1 (2)	DIN1		RCRadio1
12				RC3	ANA3	DIN3		Unused
5	GND							
13	GND							
6			CANL					CAN Low
14	5VOut							
7			CANH					CAN High

TABLE 5.

Connector Pin	Power	Dout	Com	RC	Ana	Dinput	Enc	Default Config
15				RC6 (1)(2)	ANA6 (1)	DIN6 (1)	ENCB (3)	Encoder (3)
8				RC2	ANA2	DIN2		Unused

Note 1: Not available in MBL1630CN and MBL1650CN.

Note 2: Pin assignment for this signal may differ from other Roboteq controller models.

Note 3: Encoder input requires RC inputs 3, 4, 5 and 6 to be disabled. Encoders are enabled in factory default.

Note 4: Analog command is disabled in factory default configuration.

Default I/O Configuration

The controller can be configured so that practically any Digital, Analog and RC pin can be used for any purpose. The controller's factory default configuration provides an assignment that is suitable for most applications. The figure below shows how to wire the controller to an analog potentiometer, an RC radio, the RS232 port, and the Digital output to a motor brake solenoid. You may omit any connection that is not required in your application. The controller automatically arbitrates the command priorities depending on the presence of a valid command signal in the following order: 1-RS232, 2-RC Pulse, 3-None. If needed, use the Roborun+ PC Utility to change the pin assignments and the command priority order.

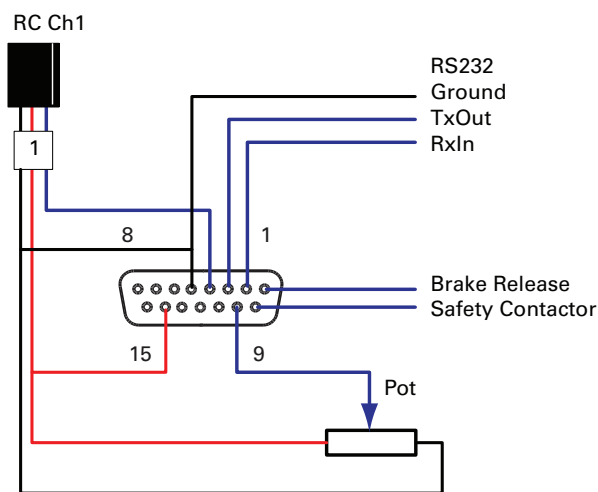

FIGURE 14. Factory default pins assignment

Enabling Analog Commands

For safety reasons, the Analog command mode is disabled by default. To enable the Analog mode, use the PC utility and set Analog in Command Priority 2 or 3 (leave Serial as priority 1). Note that by default the additional securities are enabled and will prevent the motor from starting unless the potentiometer is centered, or if the voltage is below 0.25V or above 4.75V. The drawing shows suggested assignment of Pot 1 to ANA1. Use the PC utility to enable and assign analog inputs.

CAN Bus Operation

The controller can interface to a standard CAN Bus network, using 3 possible protocols: Standard CANOpen, and two simplified proprietary schemes (MiniCAN and RawCAN). Please refer to the User Manual for details. USB and CAN cannot operate at the same time. The controller starts up with CAN available, but CAN will be disabled as soon as the controller is plugged into USB. To re-enable CAN, disconnect USB and restart the controller.

TABLE 6.

Parameter	Measure point	Model	Min	Typ	Max	Units
Humidity	Case				100 (2)	%

Note 1: Maximum regeneration voltage in normal operation. Never inject a DC voltage from a battery or other fixed source
 Note 2: Non-condensing

Power Stage Electrical Specifications (at 25oC ambient)

TABLE 7.

Parameter	Measure point	Model	Min	Typ	Max	Units
Battery Leads Voltage	Ground to VMot	MBL1630	0 (1)		30	Volts
		MBL1650	0 (1)		50	Volts
Motor Leads Voltage	Ground to U, V, W wires	MBL1630	0 (1)		30 (2)	Volts
		MBL1650	0 (1)		50 (2)	Volts
Power Control Voltage	Ground to Power Control wire	All	0 (1)		65	Volts
Minimum Operating Voltage	VMot or Pwr Ctrl wires	All	9 (3)			Volts
Over Voltage protection range	Ground to VMot	MBL1630	5	30 (4)	30	Volts
		MBL1650	5	50 (4)	50	Volts
Under Voltage protection range	Ground to VMot	MBL1630	0	5 (4)	30	Volts
		MBL1650	0	5 (4)	50	Volts
Idle Current Consumption	VMot or Pwr Ctrl wires	All	50	100 (5)	150	mA
ON Resistance (Excluding wire resistance)	VMot to U, V or W. Ground to U, V or W	All		3		mOhm
Max Current for 30s	Motor current	All			120 (6)	Amps
Continuous Max Current per channel	Motor current	All			80 (7)	Amps
Current Limit range	Motor current	All	10	80 (8)	120	Amps
Stall Detection Amps range	Motor current	All	10	120 (8)	120	Amps
Stall Detection timeout range	Motor current	All	1	65000 (9)	65000	milli-seconds
Short Circuit Detection threshold (10)	Between Motor wires or Between Motor wires and Ground	All	200 (11)		500 (11)	Amps
Short Circuit Detection threshold	Between Motor wires and VMot	All	No Protection. Permanent damage will result			
Motor Acceleration/Deceleration range	Motor Output	All	100	500 (12)	65000	milli-seconds

Note 1: Negative voltage will cause a large surge current. Protection fuse needed if battery polarity inversion is possible
 Note 2: Maximum regeneration voltage in normal operation. Never inject a DC voltage from a battery or other fixed source
 Note 3: Minimum voltage must be present on VMot or Power Control wire
 Note 4: Factory default value. Adjustable in 0.1V increments
 Note 5: Current consumption is lower when higher voltage is applied to the controller's VMot or PwrCtrl wires
 Note 6: Max value is determined by current limit setting. Duration is estimated and is dependent on ambient temperature cooling condition
 Note 7: Estimate. Limited by heatsink temperature. Current may be higher with better cooling

TABLE 7.

Parameter	Measure point	Model	Min	Typ	Max	Units
Note 8: Factory default value. Adjustable in 0.1A increments						
Note 9: Factory default value. Time in ms that Stall current must be exceeded for detection						
Note 10: Controller will stop until restarted in case of short circuit detection						
Note 11: Sensitivity selectable by software						
Note 12: Factory default value. Time in ms for power to go from 0 to 100%						

Command, I/O and Sensor Signals Specifications

TABLE 8.

Parameter	Measure point	Min	Typ	Max	Units
Main 5V Output Voltage	Ground to 5V pin on DSub15	4.7	4.9	5.1	Volts
5V Output Current	5V pin on DSub15			100	mA
Digital Output Voltage	Ground to Output pins			40	Volts
Digital Output Current	Output pins, sink current			1	Amps
Output On resistance	Output pin to ground		0.75	1.5	Ohm
Output Short circuit threshold	Output pin	1.05	1.4	1.75	Amps
Input Impedances	AIN/DIN Input to Ground		53		kOhm
Digital Input 0 Level	Ground to Input pins	-1		1	Volts
Digital Input 1 Level	Ground to Input pins	3		15	Volts
Analog Input Range	Ground to Input pins	0		5.1	Volts
Analog Input Precision	Ground to Input pins		0.5		%
Analog Input Resolution	Ground to Input pins		1		mV
Pulse durations	Pulse inputs	20000		10	us
Pulse repeat rate	Pulse inputs	50		250	Hz
Pulse Capture Resolution	Pulse inputs		1		us
Frequency Capture	Pulse inputs	100		10000	Hz
Encoder count	Internal	-2.147		2.147	10 ⁹ Counts
Encoder frequency	Encoder input pins			1M(1)	Counts/s
Note1: Encoder input requires RC inputs 3, 4, 5 and 6 to be disabled. Encoders are enabled in factory default.					

Operating & Timing Specifications

TABLE 9.

Parameter	Measure Point	Min	Typ	Max	Units
Command Latency	Command to output change	0	2.5	5	ms
PWM Frequency	Motor outputs	10	18 (1)	20	kHz
Closed Loop update rate	Internal		200		Hz
RS232 baud rate	Rx & Tx pins		115200 (2)		Bits/s
RS232 Watchdog timeout	Rx pin	1 (3)		65000	ms
Note 1: May be adjusted with configuration program					
Note 2: 115200, 8-bit, no parity, 1 stop bit, no flow control					
Note 3: May be disabled with value 0					

Scripting

TABLE 10.

Parameter	Measure Point	Min	Typ	Max	Units
Scripting Flash Memory	Internal		8192		Bytes
Max Basic Language programs	Internal		1000	1500	Lines
Integer Variables	Internal			1024	Words (1)
Boolean Variables	Internal			1024	Symbols
Execution Speed	Internal	50 000	100 000		Lines/s
Note 1: 32-bit words					

Thermal Specifications

TABLE 11.

Parameter	Measure Point	Min	Typ	Max	Units
Board Temperature	PCB	-40		85 (1)	oC
Thermal Protection range	PCB	70		80 (2)	oC
Thermal resistance	Power MOSFETs to heats sink			2	oC/W
Note 1: Thermal protection will protect the controller power					
Note 2: Max allowed power out starts lowering at minimum of range, down to 0 at max of range					

The MBL16xx uses a conduction plate at the bottom of the board for heat extraction. For best results, attach firmly with thermal compound paste against a metallic chassis so that heat transfers to the conduction plate to the chassis. If no metallic surface is available, mount the controller on spacers so that forced or natural air flow can go over the plate surface to remove heat.

Mechanical Specifications

TABLE 12.

Parameter	Measure Point	Min	Typ	Max	Units
Weight	Board		100 (3.5)		g (oz.)
Power Wire Gauge	FASTON tabs			10	AWG

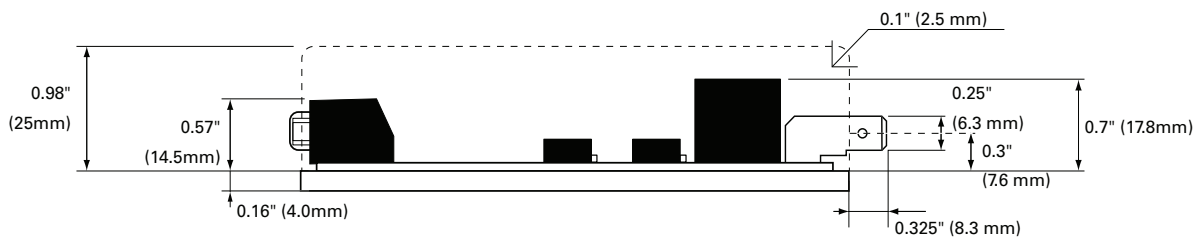

FIGURE 17. MBL16xx side view and dimensions

