

LASER 4&6

SYSTEM INTRODUCTION MANUAL

5. Product Service Information (for USA & Canada only)

In the event you would require service to your radios, please send the parts to ::

Hitec RCD USA, Inc. Service Department
12115 Paine St.
Poway, CA 92064

Please include your name address and telephone number along with a brief description of the failure or the work that you are requesting to be done.

6. Precautions

- Always turn your transmitter on first and off last.
- Never operate your system without first performing a proper range check.
- FCC regulation in the USA prohibits changing the crystal in your transmitter. For channel changes send your system to an authorized service/repair center.
- Never fly around or over houses, people or power lines.
- Always charge your batteries before you fly.
- It's a good idea to check your receiver batteries with a tester like the Hitec Power Mate II (part# 44110). This will verify the charge level in your receiver batteries.
- Always fly responsibly and respect the rights of others.
- Make sure your frequency is clear before turning on your system.

Congratulations again and have fun!

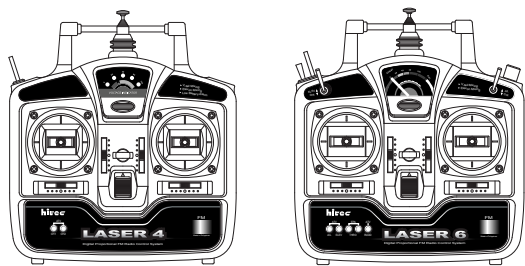

LASER 4&6

Digital Proportional FM Radio Control System

CE 06810

Austria, Belgium, Denmark, Finland,
France, Germany, Greece, Iceland,
Ireland, The Netherlands, Italy, Spain,
Norway, Portugal, United Kingdom,
Luxembourg, Sweden, Switzerland

hitec
www.hitecrccd.com

English (영어) Version 2

LASER 4&6

Digital Proportional FM Radio Control System

SYSTEM INTRODUCTION MANUAL

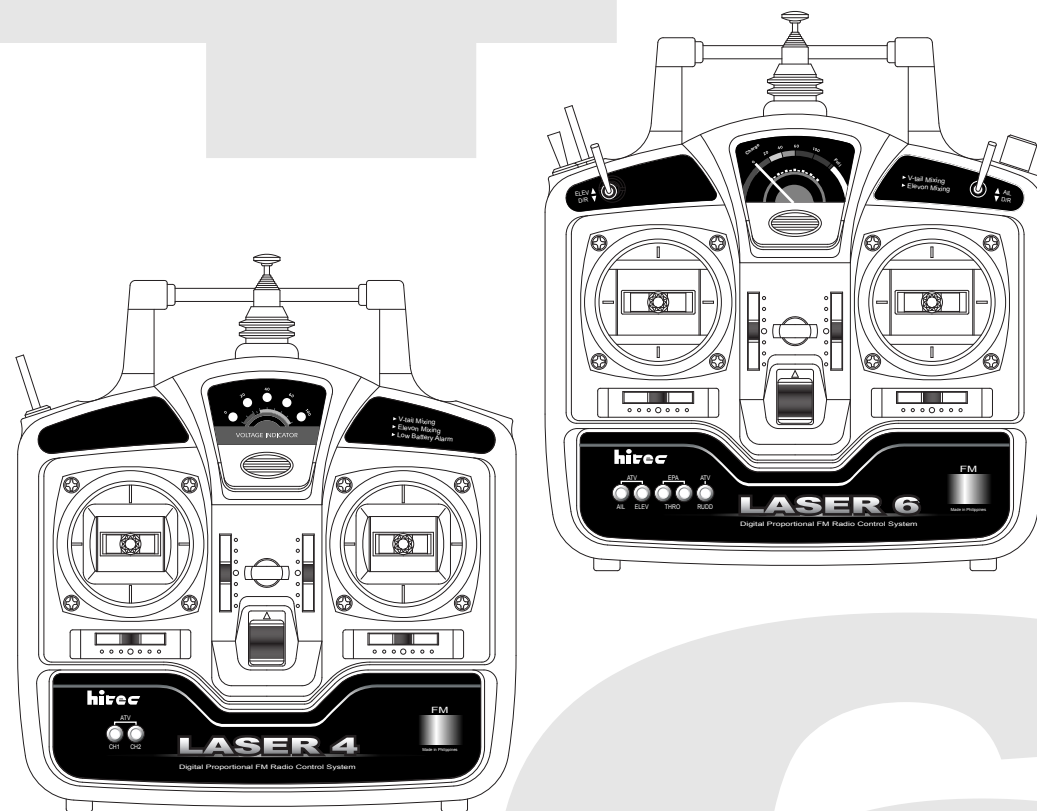

The R/Cer's Partner

hitec
www.hitecrccd.com

Introduction

Thank you for purchasing the Hitec Laser digital proportional radio control system. The Laser is loaded with features, easy to use and utilizes the latest in solid-state components for unsurpassed reliability and performance. It is important that you read and understand this manual before you attempt to operate your system.

Table of Contents

3 page	1. Transmitter a. Features b. Layout c. Specifications d. Servo Reversing e. Servo A.T.V. (Adjustable Travel Volume) f. Mixing g. Control Stick adjustment h. Stick Lever tension adjustment i. Trim levers j. Dual Rates k. Landing Gear Switch l. CH. 3 Throttle E.P.A. (End Point Adjustment)
4 page	
5 page	
6 page	
7 page	2. Battery Management a. Transmitter and Receiver battery b. Transmitter Batteries
8 page	3. Operation a. Trainer system b. Range checking
8 page	4. Replacement Parts & Accessories 5. Product Service Information 6. Precautions

System Specifications

1. Transmitter

A. Features(common for Laser 4 and Laser 6)

- Ergonomically designed 4 or 6 channel FM transmitter.
- High quality precision gimbals with adjustable stick length and tension.
- Servo reversing on all channels.
- ATV (Adjustable Travel Volume) CH 1 and CH 2.
- V-tail and Elevon mixing.
- Trainer system.
- Premium 9.6v 600mA Nicad rechargeable battery pack.(Nicad version only)
- Neck strap attachment.
- Metal carrying handle.

~Feature only for Laser 4

- Easy to read 5 LED battery indicators.
- Low Battery Alarm

~Feature only for Laser 6

- Transmitter battery voltage meter.
- EPA (End Point Adjustment) on CH 3.
- Dual rates on CH 1 Aileron and CH 2 Elevator
- ATV on CH 4

B. Layout (LASER 4 front)

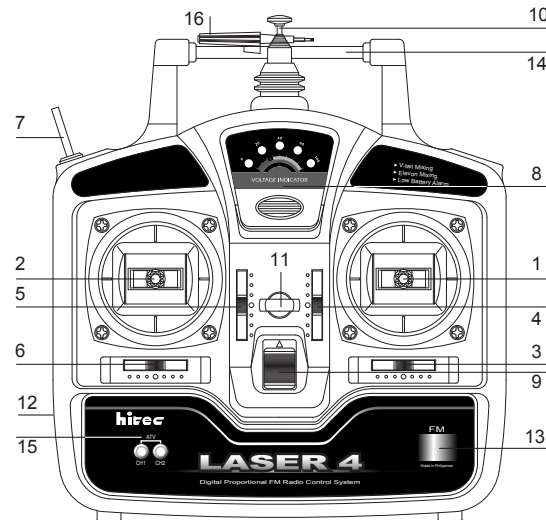

1. Aileron/Elevator stick in MODE II
2. Throttle/Rudder stick in MODE II
3. Aileron trim
4. Elevator trim
5. Throttle trim
6. Rudder trim
7. Trainer ON-OFF switch
8. LED indicator
9. Power switch
10. Rod antenna
11. Neck-strap connector
12. Recharge Jack
13. Crystal
14. Handle
15. Aileron & elevator adjustable travel volume(A.T.V)
16. Screw Driver

Layout (LASER 6 front)

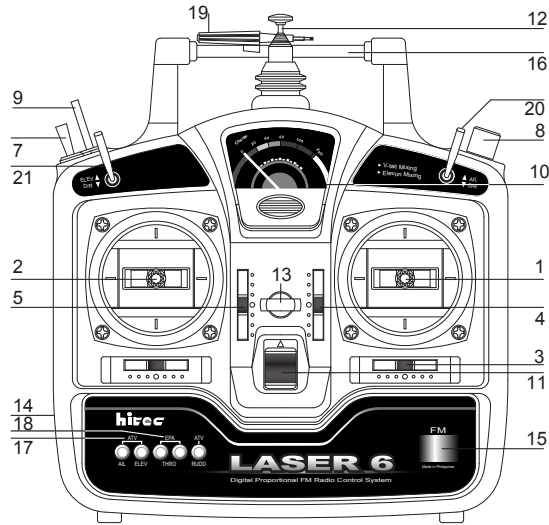

1. Aileron/Elevator stick in MODE II
2. Throttle/Rudder stick in MODE II
3. Aileron trim
4. Elevator trim
5. Throttle trim
6. Rudder trim
7. Landing gear switch
8. Flap variable switch
9. Trainer ON-OFF switch
10. Voltage meter
11. Power switch
12. Rod antenna
13. Neck-strap connector
14. Recharge Jack
15. Crystal
16. Handle
17. Aileron & elevator and rudder adjustable travel volume(A.T.V.)
18. Throttle end point adjustment high & low(E.P.A)
19. Screw Driver
20. Aileron & dual rate S/W
21. Elevator dual rate S/W

Layout (LASER 4&6 back)

1. Trainer Jack
2. Nicad-battery

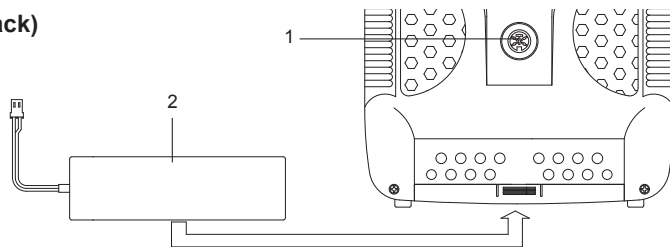

Layout (LASER 4&6 bottom)

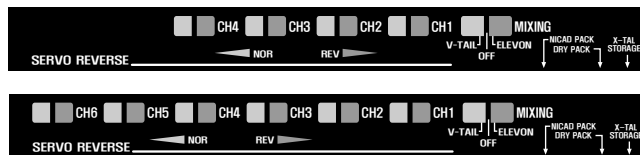

LASER 4

LASER 6

C. Specifications

- Power supply : 9.6V (8 cell) Nicad battery or 12V 8cell Dry battery
- Current drain : 150mA
- Output power : 500mw
- Modulation : PPM (FM)

D. Servo Reversing

- The Laser 4/6 FM transmitter is equipped with servo reversing on all channels.
- Leaving the switch in the middle will cause the radio to work erratically so please make sure the switches are all pushed to the furthest end.

E. Adjustable Travel Volume (A.T.V.)

- CH 1 & CH 2 for Laser 4&6, CH4 for only Laser 6.
- This function adjusts the servo overall travel on CH 1 and CH 2.
- The rate setting is adjustable from 30% to 110%.



F. Mixing

- The Laser series transmitters are equipped with a switch that will mix ch.2 & ch.4 for V-tail aircraft or ch.1 and ch.2 for Eleveon, or common flying wing type aircraft.

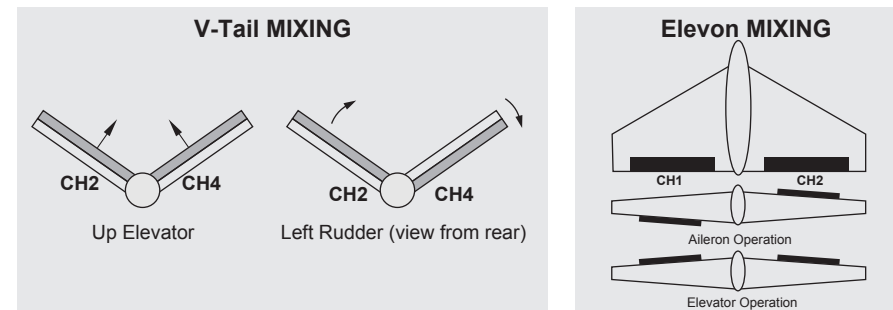

G. Control Stick Adjustment

- The length of the non-slip control sticks can be adjusted to suit the requirements of the user.

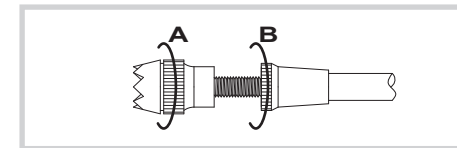

H. Stick Lever Tension Adjustment

- The unique open-stick assembly provides fully adjustable stick tension to adjust the "feel" of the sticks in your hands.
- You may adjust the stick tension of your sticks to provide the "feel" that you like for flying. To adjust your springs, you'll have to remove the rear case of the transmitter. Using a screwdriver, remove the six screws that hold the transmitter's rear cover into position, and put them in a safe place. Gently ease off the transmitter's rear cover and move it to the right side of the transmitter, carefully turning it as you would turn the page of a book. Now you'll see the view shown in the illustration. Using a small Philips screwdriver, rotate the adjusting screw for each stick for the desired spring tension. The tension increases when the adjusting screw is turned clockwise, and decreases for counterclockwise motion. When you are satisfied with the spring tensions, you may close the transmitter. Very carefully reinstall the rear cover. When the cover is properly in place, tighten the six screws.

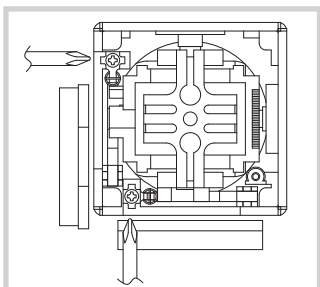

Laser 4 Stick Lever Tension

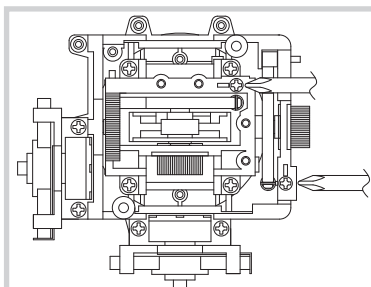

Laser 6 Stick Lever Tension

I. Trim Levers

- The trim levers associated with each control stick are used to correct or (trim-out) the tracking of the aircraft.
- (Caution) Make sure the trims will move the surface past neutral when moved to their extremes. This will assure you have adequate trim control.
- After your plane's first test flight, note the positions of the control surfaces that required trim. Next, center the trims and turn the receiver off. Now adjust the control linkage on the plane so the surfaces are in the same position before the trim levers were re-centered.
- Turn on the radio and receiver and recheck the control surfaces to ensure that all the corrections were applied in the proper direction.

J. Dual Rates (Available on Laser 6 only)

- The Laser 6 offers the user a choice of 2 rates on CH 1, aileron and CH 2, elevator. Dual rates are used to lessen and increase the servo "throw" or movement of the control surface while in flight. For example, a plane traveling very fast will require small servo or stick movements and should be flown on "low rates". While the same plane, flown slower might require more servo throw and could be flown on higher rates.

- Adjusting the Dual Rates

- With the dual rate switch in the low position, you will have full, or 100% throw. When adjusting for a lower rate, move the Aileron dual rate switch up to the higher position. Fully deflect the control surface with the transmitter stick to the left or right and hold it there. Then adjust the "pot" located on the lower left corner of the transmitter case with the provided screwdriver. You will see the control surface move when you turn the pot, adjust it accordingly. Repeat this process to adjust the Elevator dual rate setting.

K. Landing Gear Switch (Available on Laser 6 only)

- The landing gear switch will operate a servo in the CH 5 slot of the receiver. This is typically used for air or mechanically operated landing gear, which is not proportional.

L. End Point Adjustment (E.P.A) (Available on Laser 6 only)

- CH 3. (Throttle)
- This function allows for individual adjustment of the high and low throttle servo end points. Adjust the pots on the face of the radio with the provided screwdriver to position the throttle servo so it does not bind or "buzz" when at high or low stick.

2. Battery Management

A. Transmitter/Receiver battery charging

- The initial charge on your system should be at least 24 hours to ensure a full charge.
- Subsequent charges should be at least 12 - 20 hour.
- It is best to put your system (TX and RX) on charge the night before you plan to use it.
- To charge your batteries, first make sure your transmitter and receiver are off; then connect the wall charger outputs to the charging jack on the transmitter and the charge receptacle on the switch harness or directly to the battery. Make sure the green (TX) and red (RX) lights come on. If it does not, check for proper connection and/or power to the outlet.
- Be careful not to leave your transmitter or receiver battery on charge for more than 24 hours to prevent any damage to the battery or charger.
- Always charge your system before you go out to fly.

B. Battery Spacer

- Pull out the tab of the provided battery spacer first whenever you are taking the battery packs out.
- The size of nicad packs (part# 58207) are smaller than dry battery packs (part# 58101) so plug in the battery spacer into the correct slots so that the battery pack is held tight in its place.

3. Operation

A. Trainer system

- The Laser 4/6 is equipped with a trainer system that allows for master, student control
- Use trainer cord, part# 58310
- When setting up the trainer system, make sure the student radio is set up properly so the trims and servo reversing are the same as the master.
- To activate the trainer system and transfer control to the student pull and hold the trainer switch located on the top left of the transmitter. Releasing the switch will restore immediate control back to the master.

B. Range checking

- Always perform a range check before each operation.
- Perform range check by walking away from the aircraft with the transmitter antenna collapsed.
- You should have complete control from a distance of 60 - 90ft (20 - 30m).
- If the controls are erratic before the minimum distance is reached, do not fly until the problem is resolved.

4. Replacement Parts & Accessories

The following is a listing of replacement parts and accessories available for the Laser radio series from your hobby dealer.

- | | |
|---|--|
| A. TX Antenna (#58005) | H. Neck strap (#58311) |
| B. TX Nicad Battery battery pack (#58101) | I. Trainer cord (#58310) |
| D. RX Nicad Battery 600mah (#57401) | J. Switch harness (#57215S) |
| E. RX Nicad Battery 1,100mah (#57404) | K. Heavy duty gold pin switch harness (#54407) |
| F. RX Nicad Battery 270mah (#57405) | L. Stick extensions (#56381) |
| G. Overnight Charger (#43025) | M. Flight Preserver (#58480) |