

# Heli-Max™



**NOVUS**  
FP



**NOVUS**  
CX

## *Novus FP Specifications*

<b>Length:</b>	9.0 in [229mm]
<b>Width:</b>	1.6 in [41mm]
<b>Height:</b>	3.0 in [76mm]
<b>Rotor Span</b>	7.9 in [200mm]
<b>Flying Weight:</b>	1.8 oz [51.3g] (with supplied flight battery)

## *Novus CX Specifications*

<b>Length:</b>	8.0 in [205mm]
<b>Width:</b>	1.6 in [40mm]
<b>Height:</b>	5.1 in [130mm]
<b>Rotor Span</b>	6.9 in [175mm]
<b>Flying Weight:</b>	1.85 oz [52.6g] (with supplied flight battery)

## **IMPORTANT PRECAUTIONS**

- Only use the included charger with the included battery or replacement part (GPMP0408).
- Do not attempt to use this charger with NiCd or NiMH battery packs.
- Never charge in excess of 4.20V per cell.
- If the battery should become damaged, discard the battery. Do not attempt to use a damaged battery.
- Do not leave the charger unattended while charging. Disconnect the battery and remove input power from the charger immediately if either becomes hot! However, it is normal for the charger to get warm.
- Disconnect the battery from the charger and carefully move the battery to a fireproof location if the battery begins to swell or smoke!
- Never charge at currents greater than 1C.
- Always charge in a fireproof location.
- Never trickle charge.
- Never allow the battery temperature to exceed 150° F [65° C].
- Never disassemble or modify pack wiring in any way or puncture cells.
- Never discharge below 2.75V per cell.
- Do not allow water, moisture or foreign objects into the charger.
- Do not block the air intake holes, which could cause the charger to overheat.
- Do not place the charger or any battery on a flammable surface or near a combustible material while in use.
- Do not charge on a carpet, cluttered workbench, paper, plastic, vinyl, leather, wood, or inside an R/C model.
- Never charge inside a full-sized vehicle.
- Always disconnect the battery from the charger and the power supply from the charger when not in use.
- Do not attempt to charge a battery if it is swollen or hot.
- **ALWAYS KEEP OUT OF REACH OF CHILDREN.**

## WARRANTY

Heli-Max™ guarantees this kit to be free from defects in both material and workmanship at the date of purchase. This warranty does not cover any component parts damaged by use or modification. In no case shall Heli-Max's liability exceed the original cost of the purchased kit. Further, Heli-Max reserves the right to change or modify this warranty without notice.

In that Heli-Max has no control over the final assembly or material used for final assembly, no liability shall be assumed nor accepted for any damage resulting from the use by the user of the final user-assembled product. By the act of using the user-assembled product, the user accepts all resulting liability.

If the buyer is not prepared to accept the liability associated with the use of this product, the buyer is advised to return this kit immediately in new and unused condition to the place of purchase.

To make a warranty claim, send the defective part or item to Hobby Services at this address.

Hobby Services  
3002 N. Apollo Dr., Suite 1  
Champaign, IL 61822  
USA

Include a letter stating your name, return shipping address, as much contact information as possible (daytime telephone number, fax number, e-mail address), a detailed description of the problem and a photocopy of the purchase receipt. Upon receipt of the package the problem will be evaluated as quickly as possible.

**READ THROUGH THIS INSTRUCTION MANUAL FIRST. IT CONTAINS IMPORTANT INSTRUCTIONS AND WARNINGS CONCERNING THE ASSEMBLY AND USE OF THIS MODEL.**

## TABLE OF CONTENTS

INTRODUCTION .....	4
SAFETY PRECAUTIONS .....	4
ADDITIONAL ITEMS REQUIRED .....	5
ORDERING REPLACEMENT PARTS .....	6
KIT INSPECTION .....	6
KIT CONTENTS .....	7
ASSEMBLY INSTRUCTIONS .....	8
GET THE MODEL READY TO FLY .....	9
LITHIUM BATTERY HANDLING & USAGE .....	10
PREFLIGHT .....	12
CONTROLS .....	13
FLYING .....	17
MAINTENANCE & REPAIR .....	19
EXPLODED VIEW .....	28, 30
PARTS LIST & OPTIONAL PARTS .....	29, 31

## INTRODUCTION

Thank you for purchasing the Heli-Max™ Novus Helicopter. We are certain you will get many hours of enjoyment out of this model. If you should have any questions or concerns please feel free to contact us at [helihotline@hobbico.com](mailto:helihotline@hobbico.com). For the latest technical updates or manual corrections to the Novus Helicopter visit the Heli-Max web site at:

[www.helimax-rc.com](http://www.helimax-rc.com)

Open the “Helicopters” link, and then select the Novus CX or Novus FP link. If there is new technical information or changes to this model a “tech notice” box will appear in the upper left corner of the page.

## SAFETY PRECAUTIONS

- **Failure to follow these safety precautions may result in severe injury to yourself and others.**
- Keep your face and body as well as all spectators away from the plane of rotation of the rotors whenever the battery is connected.
- Keep these items away from the rotors: loose clothing, shirt sleeves, ties, scarfs, long hair or loose objects such as pencils or screwdrivers that may fall out of shirt or jacket pockets into the rotors.

- The spinning blades of a model helicopter can cause serious injury. When choosing a flying site for your Novus Helicopter, stay clear of buildings, trees and power lines. AVOID flying in or near crowded areas. DO NOT fly close to people, children or pets. Maintain a safe pilot-to-helicopter distance while flying.

1. Your Novus Helicopter should not be considered a toy, but rather a sophisticated, working model that functions very much like a full-size helicopter. Because of its performance capabilities, the Novus Helicopter, if not assembled and operated correctly, could possibly cause injury to yourself or spectators and damage to property.
2. You must assemble the model **according to the instructions**. Do not alter or modify the model, as doing so may result in an unsafe or unflyable model. In a few cases the instructions may differ slightly from the photos. In those instances the written instructions should be considered as correct.
3. You must correctly install all R/C and other components so that the model operates correctly on the ground and in the air.
4. You must check the operation of the model before **every** flight to insure that all equipment is operating and that the model has remained structurally sound. Be sure to check linkages or other connectors often and replace them if they show any signs of wear or fatigue.
5. If you are not an experienced pilot or have not flown this type of model before, we recommend that you get the assistance of an experienced pilot in your R/C club for your first flights. If you're not a member of a club, your local hobby shop has information about clubs in your area whose membership includes experienced pilots.

We, as the manufacturer, provide you with a top quality, thoroughly tested helicopter and instructions, but ultimately the quality and flyability of your finished model depends on how you build it; therefore, we cannot in any way guarantee the performance of your completed model, and no representations are expressed or implied as to the performance or safety of your completed model.

**Remember: Take your time and follow the instructions to build a safe and enjoyable model.**

## **ADDITIONAL ITEMS REQUIRED**

Eight "AA" Alkaline Batteries for the Transmitter

- (2) SANP3500 Sanyo AA Alkaline Battery (4 pack)

## ORDERING REPLACEMENT PARTS

Replacement parts for the Heli-Max Novus Helicopter are available using the order numbers in the Parts List on pages 29 and 31. The fastest, most economical service can be provided by your hobby dealer.

To locate a hobby dealer, visit the Hobbico web site at **www.hobbico.com**. Choose "Where to Buy" at the bottom of the menu on the left side of the page. Follow the instructions provided on the page to locate a U.S., Canadian or International dealer.

Parts may also be ordered directly from Hobby Services by calling (217) 398-0007, or via facsimile at (217) 398-7721, but full retail prices and shipping and handling charges will apply. Illinois and Nevada residents will also be charged sales tax. If ordering via fax, include a Visa® or MasterCard® number and expiration date for payment. Mail parts orders and payments by personal check to:

Hobby Services  
3002 N. Apollo Drive, Suite 1  
Champaign, IL 61822

Be certain to specify the order number exactly as listed in the **Parts List**. Payment by credit card or personal check only; no C.O.D.

If additional assistance is required for any reason contact **Product Support** by e-mail at [helihotline@hobbico.com](mailto:helihotline@hobbico.com), or by telephone at (217) 398-8970.

## KIT INSPECTION

Before starting assembly, take an inventory of the Novus FP/CX to make sure it is complete, and inspect the parts to make sure they are of acceptable quality. If any parts are missing or are not of acceptable quality, or if you need assistance with assembly, contact Product Support. When reporting defective or missing parts, use the part names exactly as they are written in the **Kit Contents** list.

Heli-Max Product Support:  
3002 N. Apollo Drive, Suite 1  
Champaign, IL 61822  
Telephone: (217) 398-8970, ext. 5  
Fax: (217) 398-7721  
**E-mail: [helihotline@hobbico.com](mailto:helihotline@hobbico.com)**

## KIT CONTENTS



1. Novus FP Helicopter  
2. 3.7V LiPo Battery

3. 4-Channel 2.4GHz Transmitter  
4. 110V Wall Charger

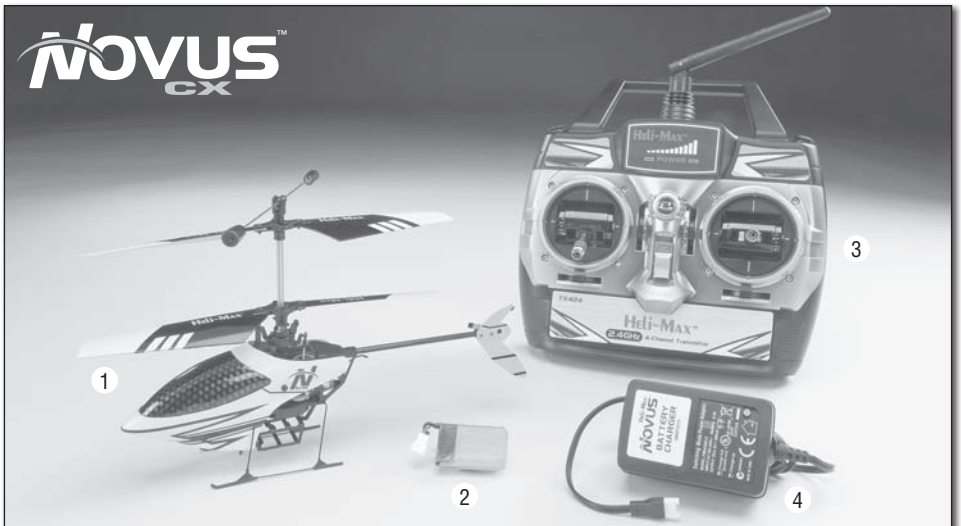

1. Novus CX Helicopter  
2. 3.7V LiPo Battery

3. 4-Channel 2.4GHz Transmitter  
4. 110V Wall Charger

# ASSEMBLY INSTRUCTIONS

## Install Batteries in the Transmitter



❑ Remove the battery cover from the back of the transmitter and remove the battery box. Install eight (8) “AA” batteries into the battery box. Double-check the polarity of each battery before placing the battery box back into the transmitter and replacing the battery cover.



❑ Turn on the transmitter using the power switch as shown above and verify that the indicator illuminates. Turn the transmitter off for now. If the indicator did not illuminate, remove the battery box from the transmitter and verify that the batteries were installed correctly.



## GET THE MODEL READY TO FLY

### Charging the Flight Battery

#### **WARNING!**

The charger supplied with the Heli-Max Novus Helicopter contains protective circuitry. If you experience any difficulties while charging the battery, please disconnect the battery from the charger and unplug the charger from the power source. Allow the battery and charger to rest for two hours as this will allow the charge protection circuit to reset. If this issue re-occurs during normal use, please contact technical support for further assistance.

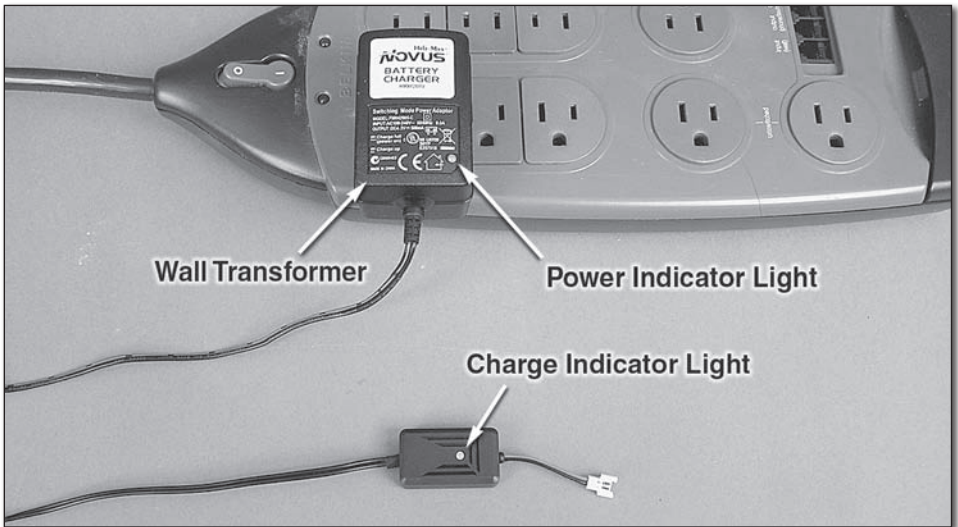

❑ Plug the wall transformer into an AC outlet. The **power indicator light** on the wall transformer will be green and the **charge indicator light** will be solid red.

#### **Charge Indicator Light**

<b>Fast Flashing Red</b>	The battery is being charged.	* Once the battery has been disconnected from the charger contact technical support for further assistance.
<b>Green (Solid or Flashing)</b>	The battery is fully charged.	
<b>*Slow Flashing Red</b>	A time-out has occurred.	
<b>*Solid Red with Battery Connected</b>	The battery voltage is too low or the charger is not powered.	
<b>Solid Red without Battery Connected</b>	The charger is ready.	

## WARNING!

**Do not leave the battery connected** to the charger if the charge indicator is solid red. This may over-discharge the battery, possibly causing damage to the battery or the charger. Once the battery has been disconnected from the charger, contact technical support immediately for further assistance.

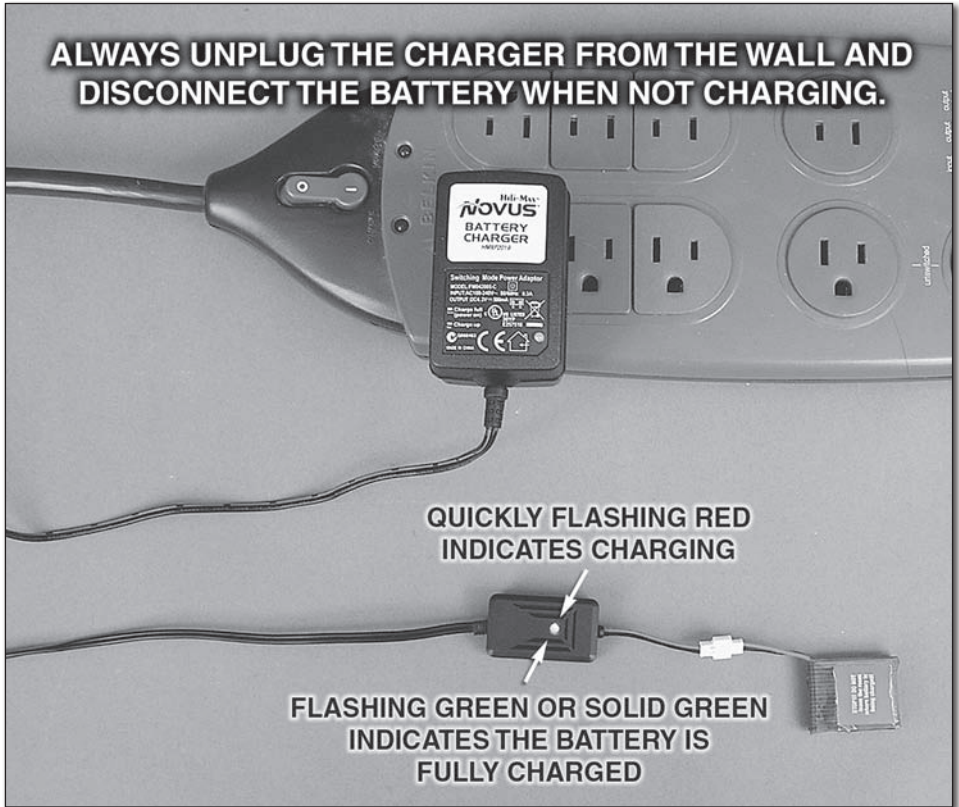

- ❑ Plug the battery into the charger. The charge indicator light will start flashing red quickly; this indicates that the battery is being charged. Once the battery is completely charged, the charge indicator light will turn green (solid or flashing). Disconnect the battery from the charger. Under normal operating conditions, the battery may take up to one hour to recharge.

## LITHIUM BATTERY HANDLING & USAGE



**WARNING!!** Read the entire instruction sheet included with this battery. Failure to follow all instructions could cause permanent damage to the battery and its surroundings, and may cause bodily harm!



**Land your model immediately when the battery begins to lose power. Recharge the battery before attempting another flight.** A dangerous situation can occur when attempting to recharge an over-discharged battery!

- ALWAYS charge the battery inside a fireproof container placed in a fireproof location clear of combustible materials. Failure to do so can result in property damage and/or bodily harm!
- ALWAYS keep charging batteries within eyesight. Leaving the battery unattended is dangerous!
- ALWAYS keep a supply of sand accessible when charging. Dumping sand on the battery will extinguish the LiPo chemical fire.
- NEVER use anything EXCEPT a LiPo approved charger.
- NEVER charge over 4.20V per cell.
- NEVER charge at currents greater than 1C.
- NEVER charge through the “To ESC” or “DISCHARGE” lead.
- NEVER trickle charge, or allow the battery to discharge below 2.75V per cell.
- NEVER allow the battery temperature to exceed 140° F [60° C].
- NEVER disassemble or modify the pack wiring in any way or puncture cells.
- ALWAYS KEEP OUT OF REACH OF CHILDREN.

### Electric Motor Warning

Electric motors are very dangerous. Do not work on the model while the flight battery is plugged in as interference may cause the main rotor blades to spin, possibly causing injury to yourself.

### Installing the Flight Battery

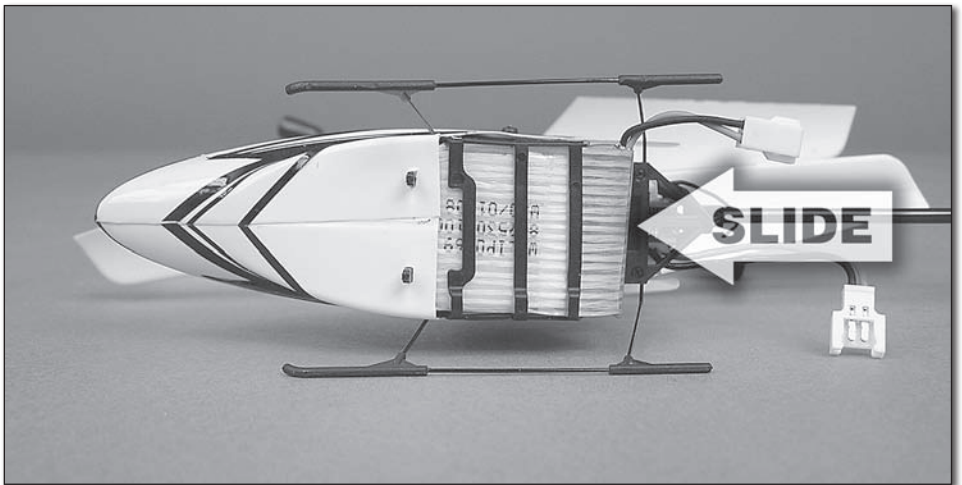

Slide the flight battery into the Novus Helicopter as shown.

## PREFLIGHT

### Turning the Model On

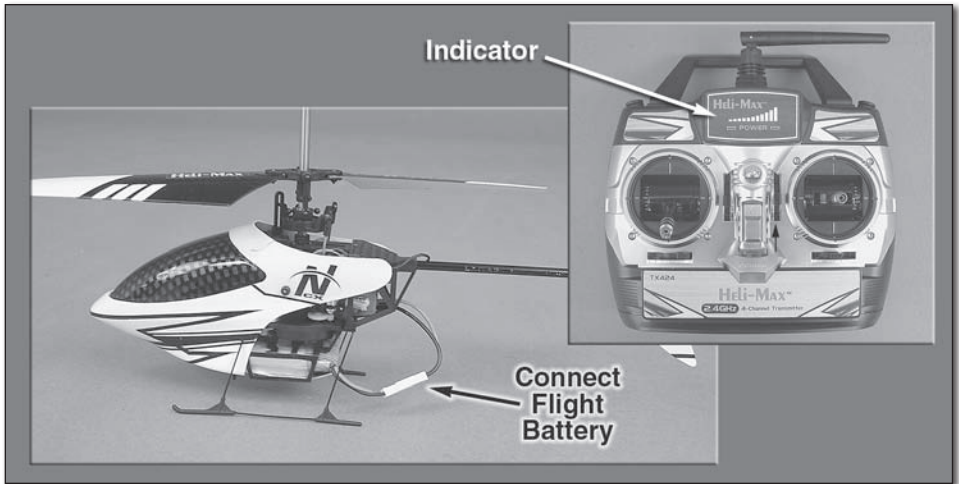

The Novus Helicopter uses a 2.4GHz system that requires a binding process when the unit is powered up. This process involves connecting the flight battery to the ESC with the transmitter turned off. Ensure that the throttle stick is at its lowest position and turn the transmitter on. You will notice that the transmitter logo begins to flash, indicating that the binding process is taking place.

Once the logo quits flashing you should see the servos move, signifying that the receiver is now bound to the transmitter. The helicopter must be left still for 5 seconds so the gyro can perform the initialization process. The Novus Helicopter is now ready for flight. Always step 15 feet [4.5m] away from the Novus Helicopter before operating the throttle. Do not hold the model while operating the throttle.

A safe start is built into the Novus Helicopter that prevents the motor from activating unless the collective stick has been lowered to the lowest position. If the motor won't run and turn the main blades, please make sure the collective stick is all the way down and leave it there for a couple of seconds. Then try moving the stick up slowly.

### Balance the Main Blades

The Novus Helicopter main rotor blades are already balanced and ready to fly.

# CONTROLS

## Transmitter Controls

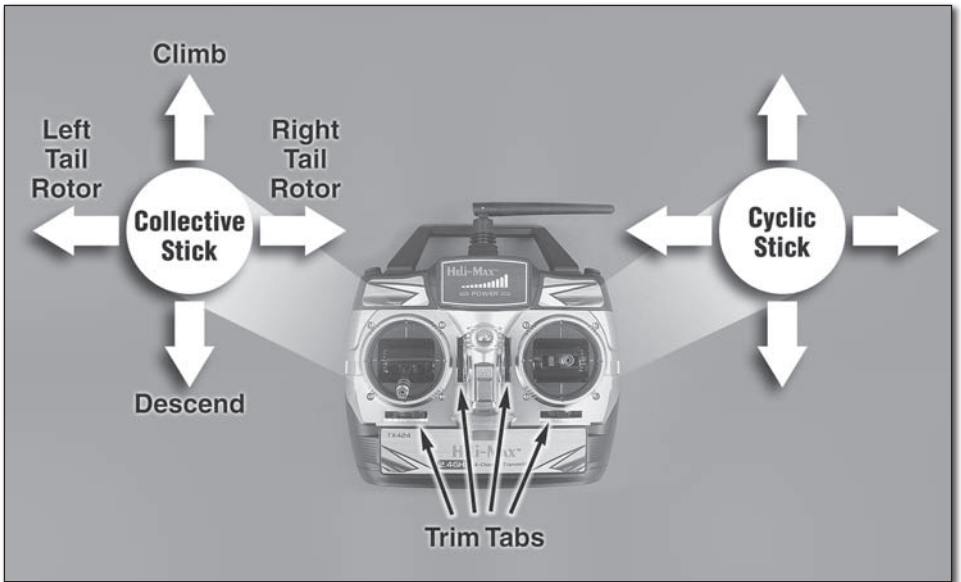

All controls described as follows are with the tail pointing directly towards you. This is the best way to start out since it keeps the control inputs oriented the same. Once you start getting comfortable you can work on side hovering and nose-in.



Moving the cyclic stick right will cause the helicopter to tilt right and start moving that direction.

**HELICOPTER  
MOVES  
LEFT**



Moving the cyclic stick left will cause the helicopter to tilt left and start moving that direction.

**HELICOPTER  
MOVES  
BACKWARDS**



Moving the cyclic stick backwards (towards you) will cause the helicopter to tilt backwards and start moving that direction.

**HELICOPTER  
MOVES  
FORWARD**



Moving the cyclic stick forward (away from you) will cause the helicopter to tilt forward and start moving that direction.

**HELICOPTER  
CLIMBS**

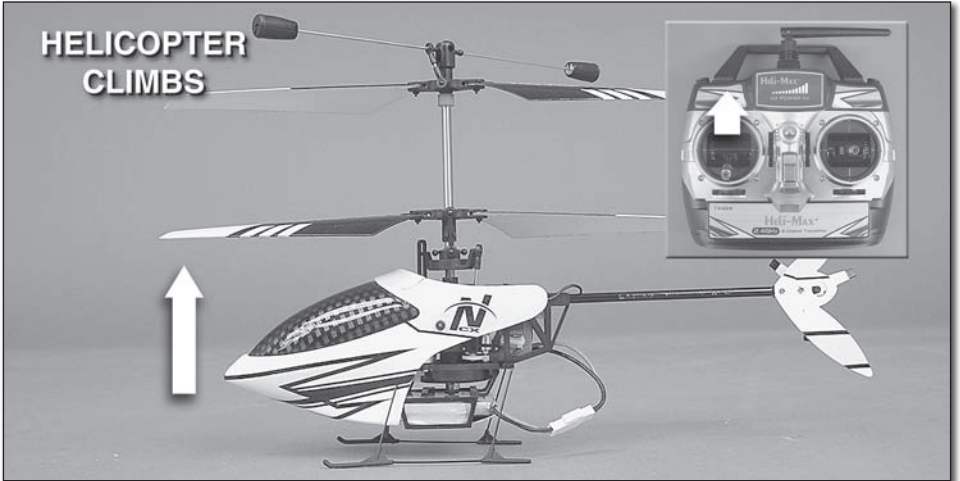

Moving the collective stick up (away from you) will cause the helicopter to climb higher.

## HELICOPTER DESCENDS

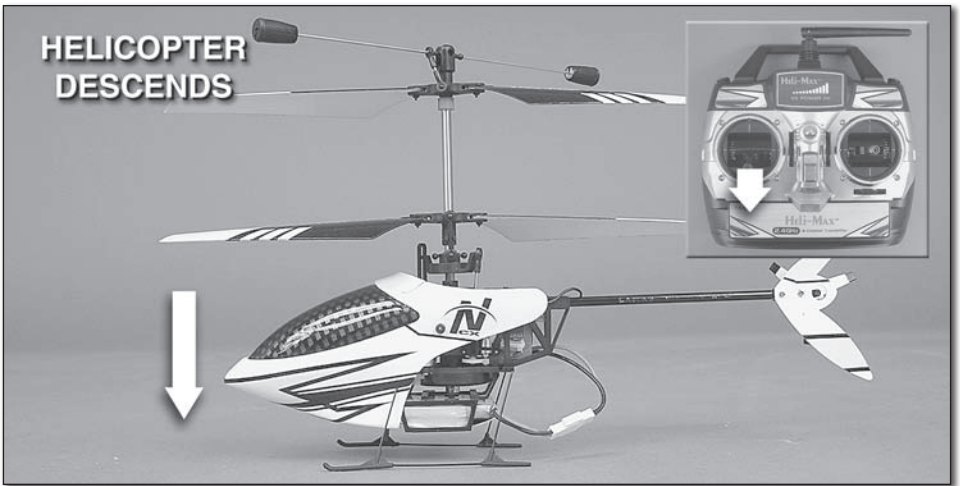

Moving the collective stick down (towards you) will cause the helicopter to descend.

## NOSE MOVES LEFT

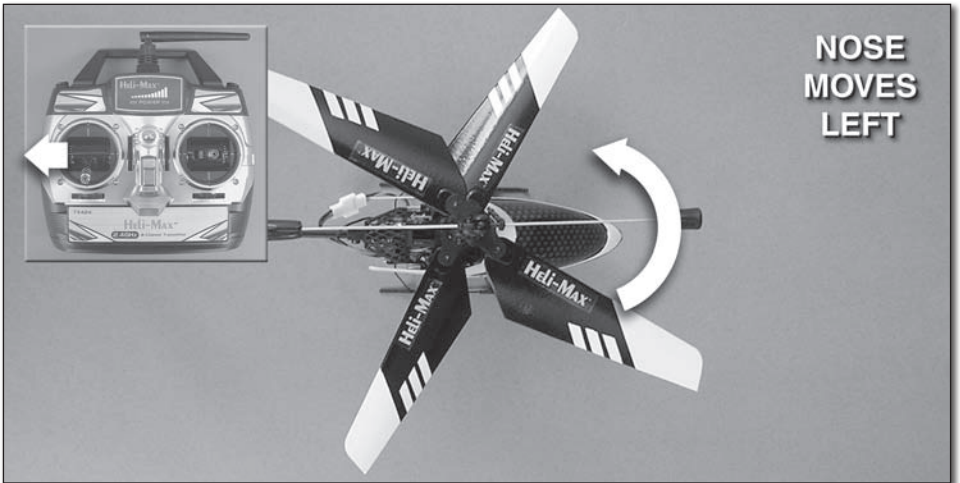

Moving the tail rotor stick towards the left will cause the helicopter nose to rotate left (counterclockwise).



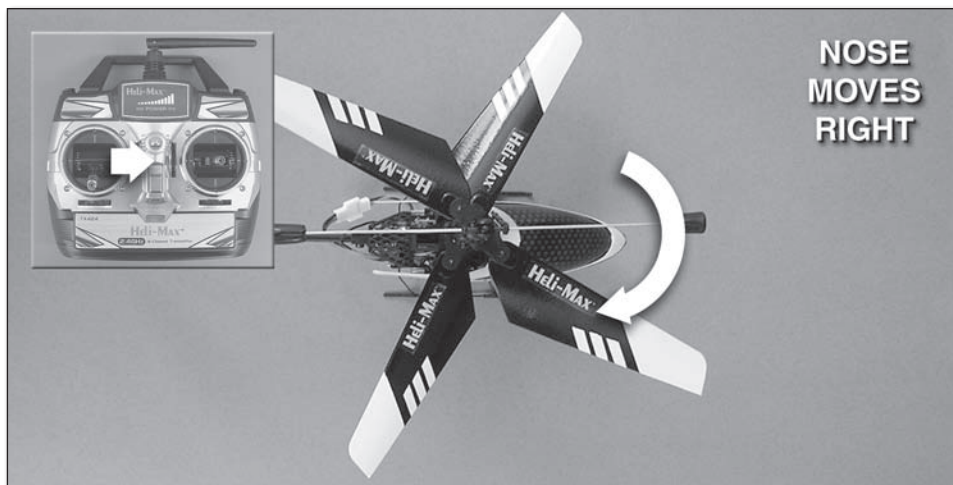

Moving the tail rotor stick towards the right will cause the helicopter nose to rotate right (clockwise).

## **FLYING**

The Heli-Max Novus CX and FP are extremely lightweight helicopters. Taking that into consideration, you should only fly the helicopter indoors or in calm winds less than 1mph.

The Novus CX coaxial helicopter is very stable and easy to fly in comparison to the Novus FP single rotor helicopter. Until you become accustomed to the Novus FP helicopter we highly recommend flying it in a large area of at least 35 feet [10.5m] square with no obstacles.

Both the Novus CX and Novus FP are extremely lightweight and do not fly well in ground effect (air disturbance when the model is hovered below 1 foot [30cm]). Both models should be flown at a minimum altitude of 1foot [30cm] to avoid the ground effect.

### **Crashing**

We already know that crashing is going to occur. Once you realize the model is going to collide with something or crash into the ground, you should always bring the throttle stick all the way down to stop the main rotor blades from rotating. If you can remember to do this, chances are you will not damage the helicopter in the crash. The main rotor blades carry a lot of RPM and inertia during flight. Cutting the power to the main rotor blades will prevent most of the crash damage.

## Takeoff

Slowly add power and observe the model. If you feel it needs trimming, do so before lift off. You will find that model helicopters never allow you to return the sticks to center. You just need to position the stick as needed to maintain a steady hover.

You will notice the cyclic controls lag behind your inputs. This is perfectly normal and something you get the feel for with time. It's normal to drift around a little in a hover until you get used to flying the model. The cyclic controls are fairly sensitive so only small movements are necessary.

## Hovering

Once the helicopter is up in the air, simply try to hold it in one spot. This can take some practice. Wind or air currents have a big effect on the stability of the helicopter as well. Be patient and slowly work forward, as trying to rush the learning process can be costly.

## Landing

Level the helicopter into a steady hover and slowly decrease power until the helicopter settles onto the ground.

## Basic Maneuvers

Once you get comfortable with hovering at different orientations and landing, it's time to move on to more advanced maneuvers.

**Slow Pirouettes** – Add a small amount of tail rotor (left or right) and try rotating the helicopter slightly sideways and see if you can hold it there. If you feel uncomfortable, then bring the tail back toward you. Once you start getting comfortable, try moving the helicopter to the side. Then turn back and fly back to the other side in straight lines. Once you get that down you can try rotating the helicopter around 360 degrees, which is called a pirouette. The helicopter can drift during these so make sure you have plenty of room when you first start practicing.

**Nose-in Hovering** – After pirouettes it's time to move on to nose-in hovering. Take off and climb to 10 feet [3m]. Practice half pirouettes from tail in to nose-in hovering and try to lengthen the delay in between. This will give you a little practice nose-in and still give you a chance to get out of trouble. As you improve you'll remain nose-in for longer periods of time.

**GOOD LUCK AND GREAT FLYING!**

## MAINTENANCE & REPAIR

The Heli-Max™ Novus CX and FP are very small helicopters. Working on these small models will require very small tools. The DTXR0170 DuraTrax® Precision Phillips Screwdriver 00x75mm is recommended for both the Novus CX and FP.

Both the Novus CX and FP are very sturdy helicopters. On occasion it will be necessary to replace damaged parts after a crash. Please use this section as a guide to performing these steps.

### **NOVUS FP – MAIN ROTOR BLADE REPLACEMENT**

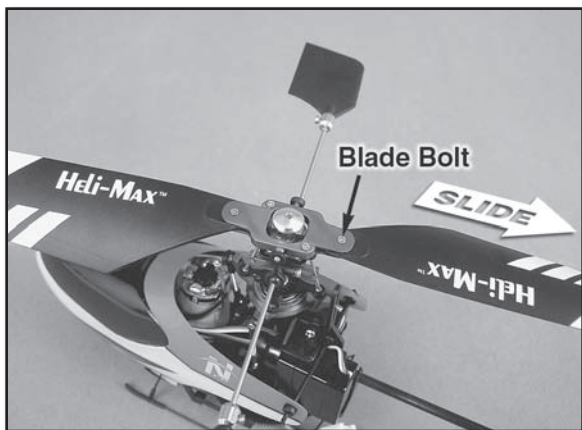

Remove the blade bolt using a #00 phillips screwdriver. After the blade bolt has been removed, slide the rotor blade out of the blade grip. Reinstall the new blade, ensuring that the holes within the blade and blade grip are aligned properly. Reinstall the blade bolt.

### **NOVUS FP – MAIN ROTOR GRIP REPLACEMENT**

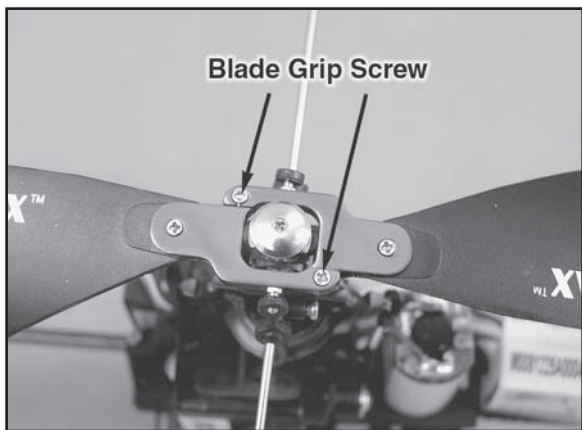

Remove both blade bolts and main rotor blades. Remove the flybar linkage from the blade grips. Remove the two blade grip screws and the blade grips can be easily removed. Reinstall the parts in the reverse order listed above.

## **NOVUS FP – REPLACING THE FLYBAR**

Loosen the screws on both flybar paddle collars. Rotate the paddles counter clockwise to remove the paddle and the collar from the flybar. Loosen the screws on

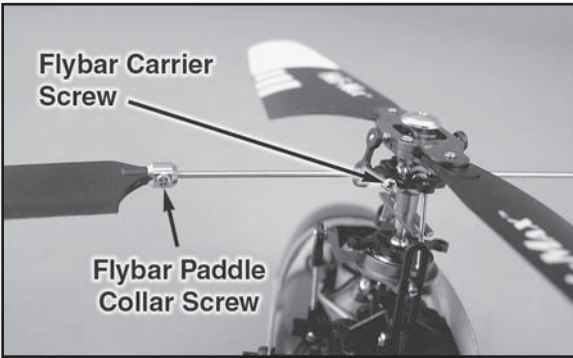

the flybar carrier (both sides). At this point the flybar can be slid out of the flybar carrier. Slide the new flybar into the flybar carrier and ensure that the new flybar is centered. Tighten the flybar carrier screws and reinstall the paddles. Ensure that the paddles are equal distances out on the flybar and tighten the flybar paddle collar screws.

## **NOVUS FP – REPLACING THE MAIN GEAR**

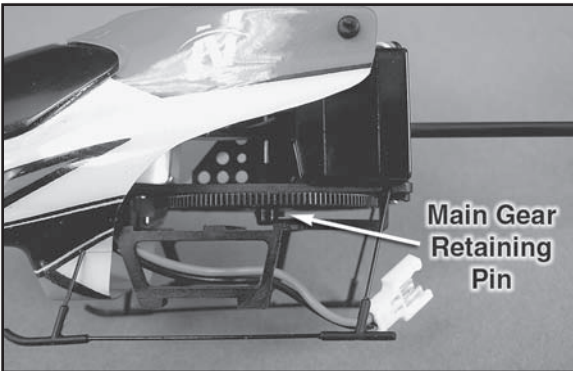

Remove the lower retaining pin from the main gear using needle nose pliers. Remove the old main gear from the model and install the new main gear. Align the hole in the main shaft with the hole in the main gear and press the small pin back through the hole.

## **NOVUS FP – REPLACING THE MAINSHAFT**

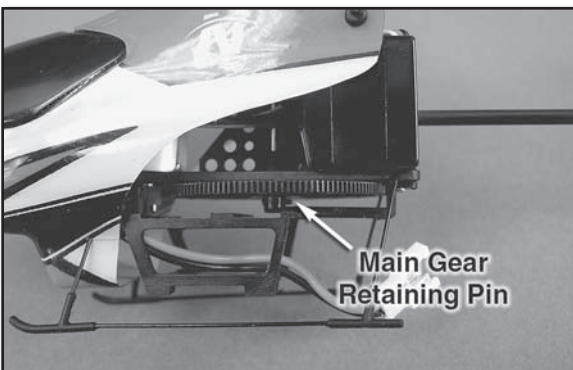

Remove the lower retaining pin from the main gear using needle nose pliers. Disconnect the servo linkages from the swashplate. Slide the main shaft straight up and out of the main frame. Remove and transfer necessary parts to the new main shaft and reinstall by reversing the order listed above.

## **NOVUS FP – REPLACING THE TAIL SHAFT AND TAIL ROTOR**

Use a flat blade screw driver to carefully pry the tail rotor from the tail rotor shaft.

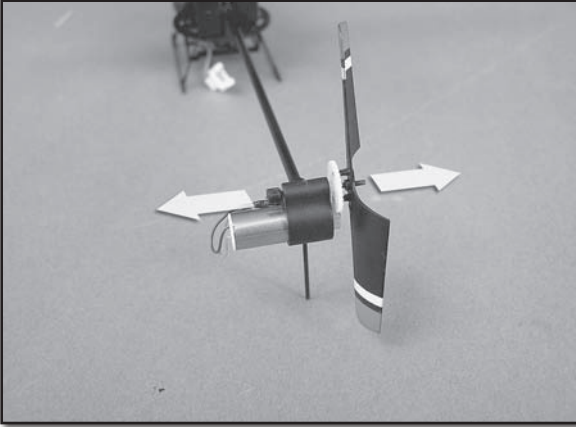

Slide the tail drive gear off of the shaft. Slide the tail rotor shaft out the opposite side of the tail rotor case. Slide the new tail rotor shaft into the tail rotor housing. Slide the tail drive gear onto the shaft (the step faces inward) and press the tail rotor onto the shaft, ensuring that the two protrusions on the tail rotor line up properly with the tail drive gear.

## **NOVUS FP – REPLACE THE TAILBOOM**

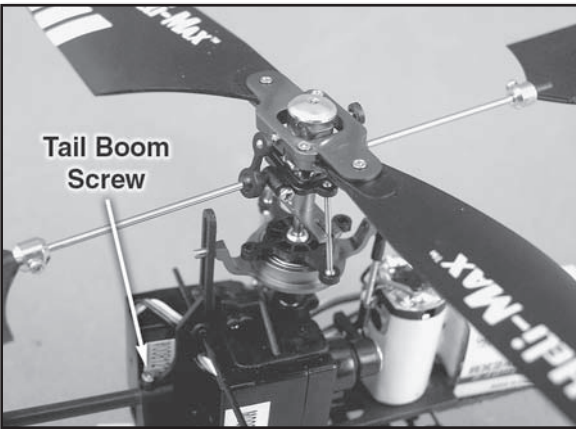

Loosen the tail boom screw and unplug the tail motor wire from the E-Board. It will be necessary to cut the motor wires near the tail motor where the heat shrink tubing has been applied. While holding onto the tail motor connector at the front, slowly slide the tail boom out of the frame and off the tail motor wires. If you notice any damage to the tail motor wires it will be necessary to replace the tail motor wire harness.

Slide the tail motor wires into the tail boom and reinstall the tail boom onto the helicopter. On the old tail boom, remove the lower tail motor retention screw and remove the tail motor gear box assembly. Run the tail motor wires through the tail motor gear box assembly. Ensure that the tail boom is pressed far enough into the main frame and tighten the tail boom screw on the main frame. Ensure that the tail gear box assembly is pressed far enough onto the tail boom and ensure that the tail rotor is vertically aligned with the main shaft. Tighten the lower tail gear box retention screw once you are certain that everything is correct. Re-solder the tail motor wires to the tail rotor wire harness and install heat shrink tubing. Ensure everything is correctly installed and all bolts have been tightened.

## **NOVUS FP – REPLACING A MOTOR**

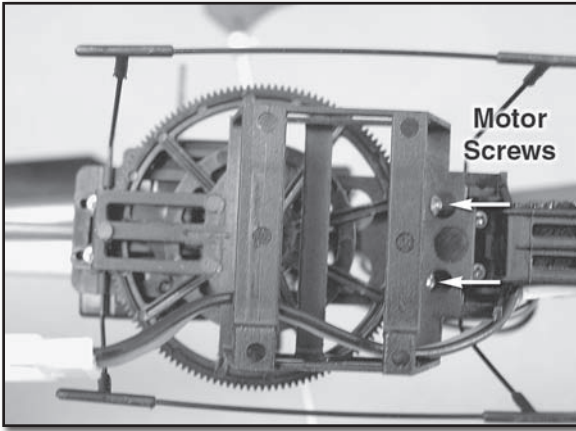

Unplug the motor from the E-Board and remove the motor mounting screws. Remove the old motor and install the new motor. Reinstall the motor mounting screws and plug the motor connector back into the E-Board.

## **NOVUS FP – E-BOARD CONNECTIONS**

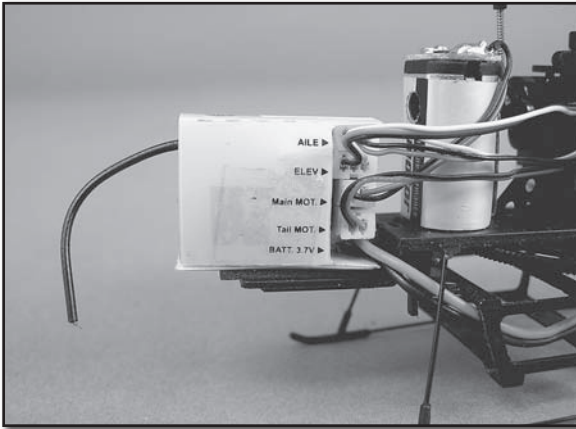

In addition to the connections there is an adjuster located on the other side of the E-Board. This adjuster is used to increase or decrease the total servo throw. This is set at the factory for the optimum setting. After you have become accustomed to the model, feel free to make adjustments to suit your flying style.

The Heli-Max™ Novus CX and FP are very small helicopters. Working on these small models will require very small tools. The DTXR0170 Duratrax Precision Phillips Screwdriver 00x75mm is recommended for both the Novus CX and FP.

### **NOVUS CX – MAIN ROTOR BLADE REPLACEMENT**

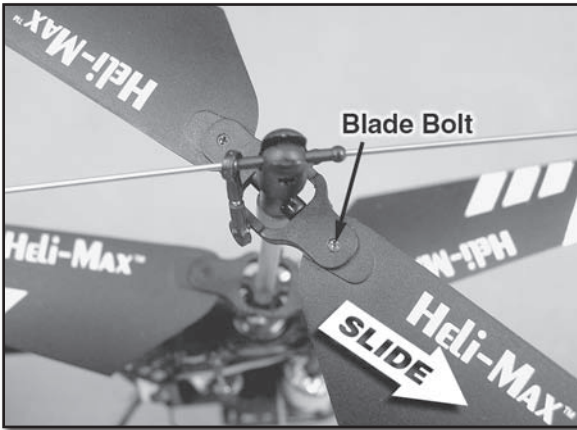

Remove the blade bolt using a #00 phillips screwdriver. After the blade bolt has been removed, slide the rotor blade out of the blade grip. Reinstall the new blade, ensuring that the hole within the blade and blade grip are aligned properly. Reinstall the blade bolt.

### **NOVUS CX – MAIN ROTOR GRIP REPLACEMENT**

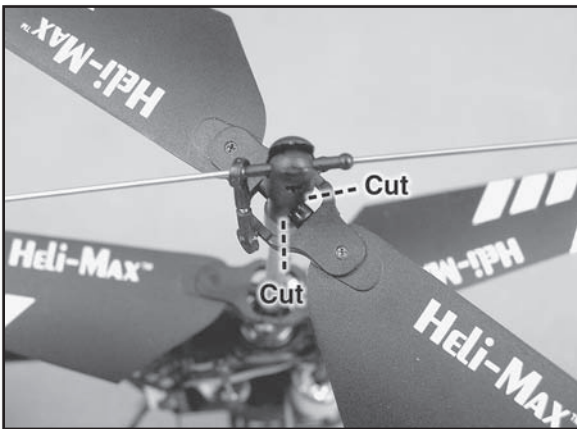

Remove both blade bolts and main rotor blades. If working on the upper rotor, remove the flybar and linkage. The only way to remove the blade grip is to cut the grip on both sides as shown. Remove the two halves. Remove the two metal pivot pins from the head block. Slide the two metal pivot pins from the center of each grip into the blade grip. Press these pins in until they are flush. Align the new blade grip on the head

block and from the outside of the grip, push the pins into the head block. Install the flybar and main rotor blades.

Hint: If you need to change the lower rotor grips it is easiest to remove the entire upper rotor head by loosening the main gear retention screw. Then, pull the upper head and shaft from the helicopter. This will allow access to the lower rotor grips.

## **NOVUS CX – REPLACING THE FLYBAR**

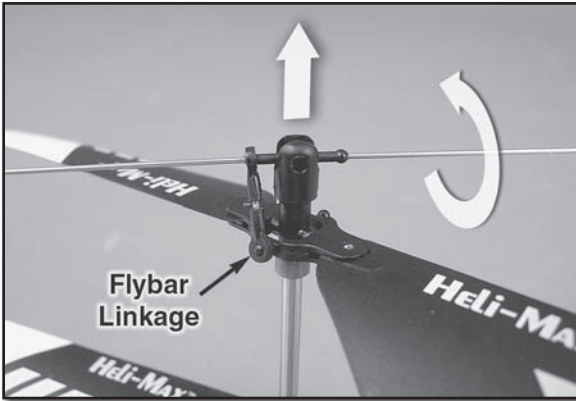

flybar weights onto the new flybar and slide the flybar pivot back onto the head block. Reinstall the flybar linkage.

Remove the flybar linkage from the blade grip. Press outward on one side of the head block and simply rotate the flybar carrier from the head block. Once the flybar carrier has been removed, press the flybar weights inward and turn them 90 degrees. Now pull them off the end of the flybar. Remove the flybar linkage from the old flybar and install the linkage onto the new flybar. Install the

## **NOVUS CX – REPLACING THE MAIN GEAR**

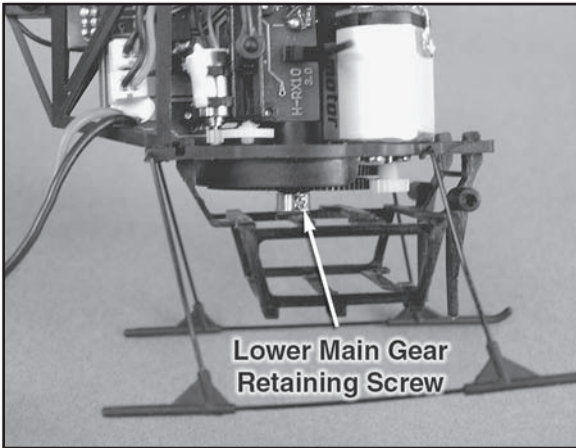

The Novus CX uses an inner solid main shaft and a hollow outer main shaft. Remove the lower main gear retaining screw. The lower gear will simply drop down off the main shaft. If you need to replace the upper main gear, slide it down off the main shaft and reinstall the new gear ensuring that the flat spot molded inside the gear aligns with the main shaft. Reinstall the lower gear ensuring that the screw aligns with the flat spot machined on the inner main shaft.



## **NOVUS CX – REPLACING THE MAINSHAFT AND UPPER HEAD**

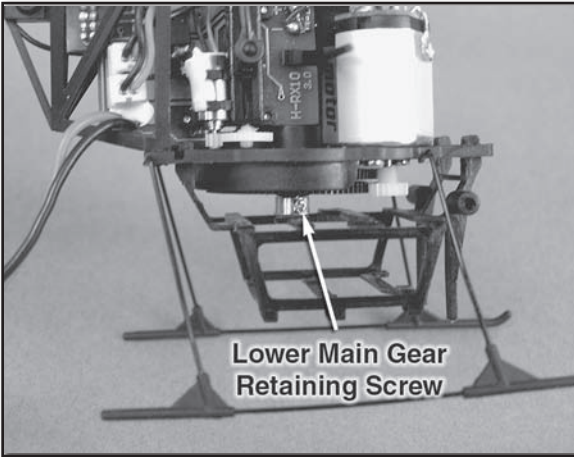

The Novus CX uses an inner solid main shaft and a hollow outer main shaft. Remove the lower main gear retaining screw. When performing the following step please be careful not to lose any small bearings or bearing blocks. Slide the inner shaft and upper rotor head from the outer main shaft by pulling upwards. If you need to remove the lower shaft, disconnect the servo linkages from the swashplate and pull upwards. Transfer necessary

parts from the old shaft to the new shaft and install following the reverse order listed above.

## **NOVUS CX – REPLACING THE TAIL SHAFT AND TAIL ROTOR**

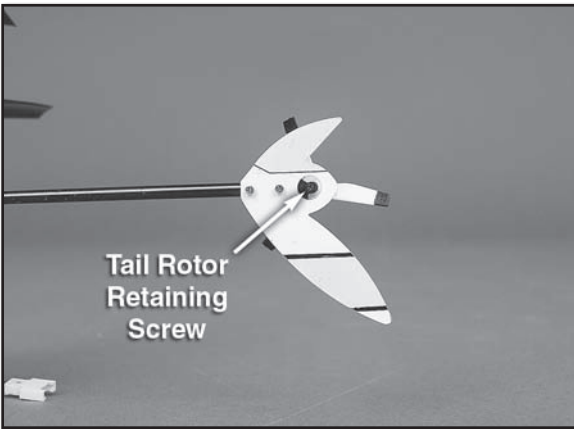

Remove the tail rotor retaining screw. Replace the tail rotor blade and reinstall the tail rotor retaining screw

## **NOVUS CX – REPLACE THE TAILBOOM**

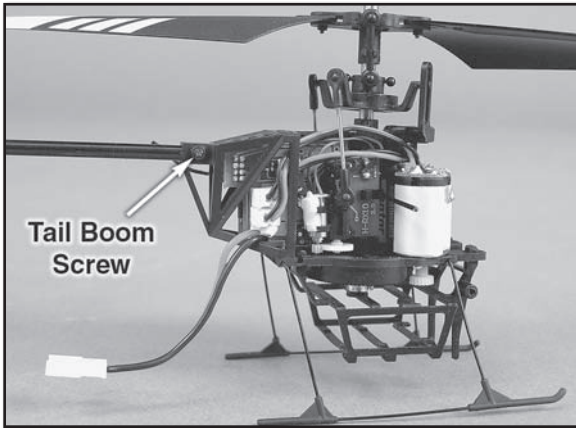

Loosen the tail boom screw and slide the tail boom out of the frame. Loosen the two screws used to attached the tail fin and tail assembly to the tail boom. Slide the tail assembly from the tail boom.

tighten the two screws used to attach the tail fin to the tail assembly. Slide the tail boom into the main frame. Ensure that the tail fin is vertically aligned with the main shaft and tighten the front tail boom screw.

## **NOVUS CX – REPLACING A MOTOR**

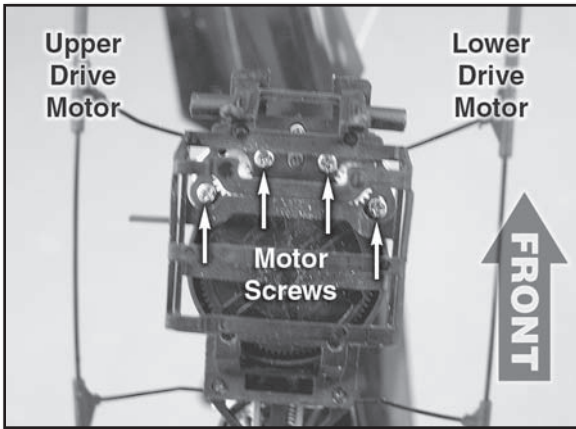

The Novus CX uses two separate drive motors. The upper blade motor is located on the left side when looking at the bottom of the helicopter with the nose facing upwards. The lower blade motor is located on the right side.

Once you have determined which motor needs replacing, unplug the motor from the E-Board, remove the appropriate motor mounting screws and install the new motor. Plug the motor connector into the E-Board.

## **NOVUS CX – E-BOARD CONNECTIONS**

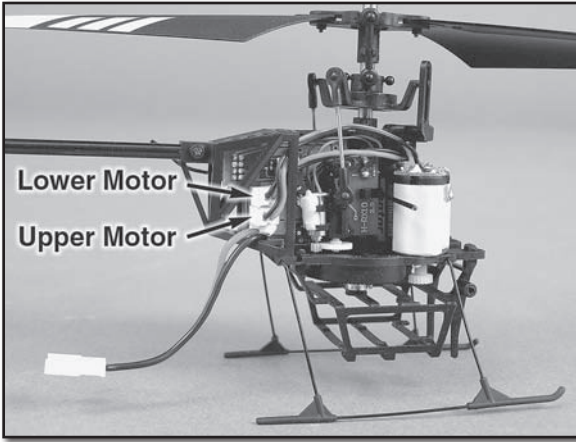

In addition to the connections there is an adjuster located on the other side of the E-Board. This adjuster is used to set the gyro gain. The factory setting is the optimum value. Due to different climates it may be necessary to make slight adjustments. If you notice the tail does not remain still, try increasing the gain. If you notice that the tail constantly oscillates back and forth, decrease the gain.

# Heli-Max™ Novus CX Exploded View

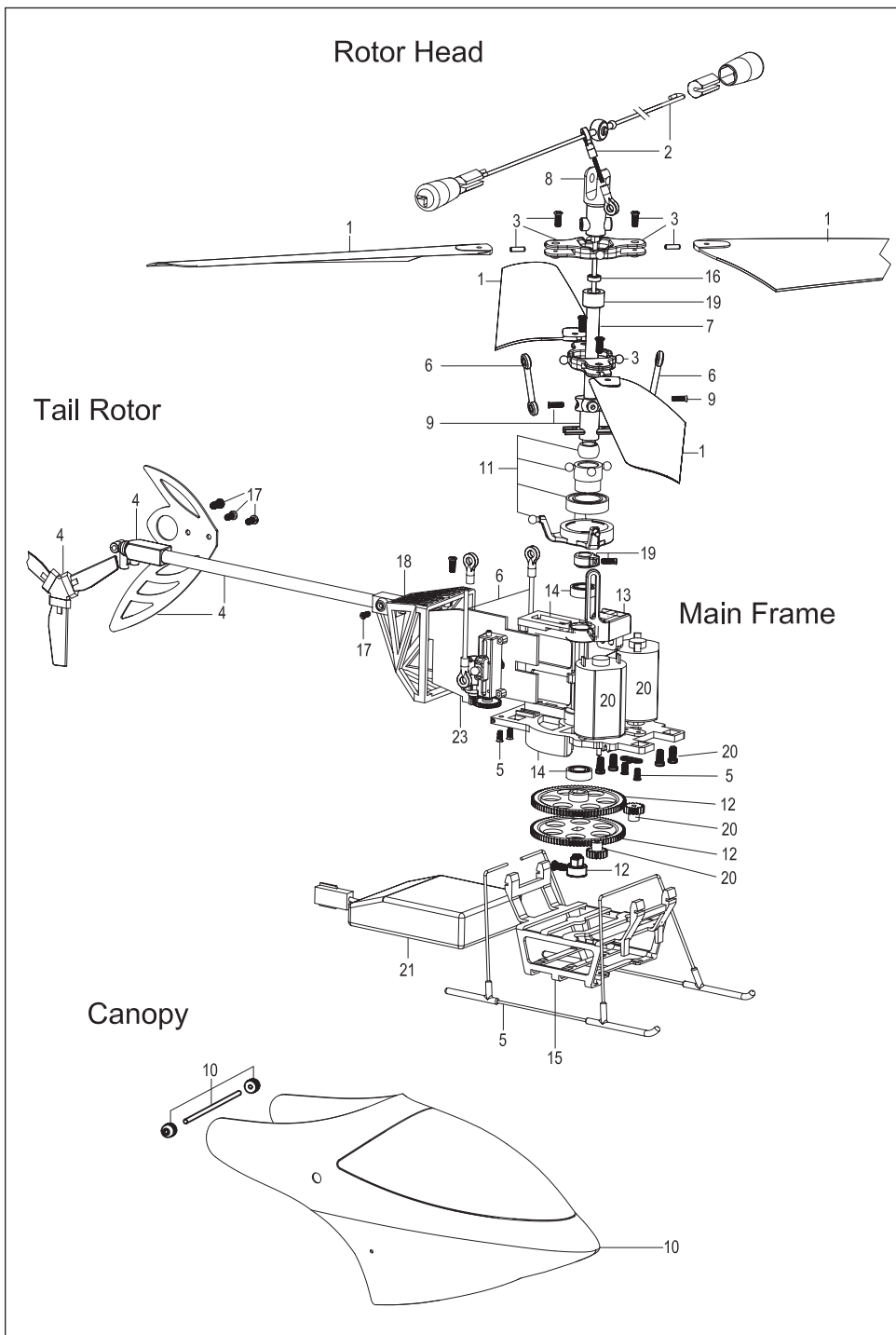

## ***Heli-Max™ Novus CX Parts List***

1. HMXE8535 . . . . Main Rotor Blades Upper and Lower (4) Novus CX
2. HMXE8536 . . . . Flybar Assembly Novus CX
3. HMXE8537 . . . . Main Blade Grips (2) Novus CX
4. HMXE8428 . . . . Tail Boom Assembly Novus CX
5. HMXE7942 . . . . Landing Gear Assembly w/ Mounting Screws Novus CX
6. HMXE8538 . . . . Ball Link Pushrod Set Servo and Swash Links Novus CX
7. HMXE8539 . . . . Outer Main Shaft Novus CX
8. HMXE8540 . . . . Inner Main Shaft Novus CX
9. HMXE8541 . . . . Lower Head Block/ Blade Drive Novus CX
10. HMXE7394 . . . . Printed Canopy Novus CX
11. HMXE8542 . . . . Swashplate Assembly Novus CX
12. HMXE8032 . . . . Upper and Lower Main Drive Gears Novus CX
13. HMXE8543 . . . . Swashplate AntiRotation Stay Novus CX
14. HMXE7944 . . . . Main Frame Novus CX
15. HMXE7943 . . . . Battery Tray Novus CX
16. HMXE8829 . . . . Ball Bearing Set Novus CX
17. HMXE7329 . . . . Complete Screw Set Novus CX
18. HMXE8429 . . . . Rear Subframe Novus CX
19. HMXE8544 . . . . Locking Sleeve Assembly Novus CX
20. HMXG8008 . . . . Main Drive Motors Upper and Lower Novus CX
21. GPMP0408 . . . . 1S LiPo 400 mAh Battery Novus CX/FP
22. HMXP2019 . . . . 1S LiPo Charger Novus CX/FP
23. HMXM2020 . . . . 5 in 1 RX/ ESC/ Gyro/ 2 Servos Control Board Novus CX
24. HMXJ2021 . . . . 4Ch 2.4 GHz Transmitter Novus CX/ FP

## ***Novus CX Option Parts***

- HMXE7468 . . . . CNC Main Blade Grips Upper and Lower Novus CX  
HMXE7469 . . . . Outer Shaft w CNC Retainer Collar Novus CX  
HMXE7470 . . . . CNC Head Block W Inner Rotor Shaft Novus CX  
HMXE7471 . . . . CNC Swashplate Assembly Novus CX  
GPMM3150 . . . . Charge Lead Banana to HMX Micro Plug

# Heli-Max Novus FP Exploded View

## Rotor Head

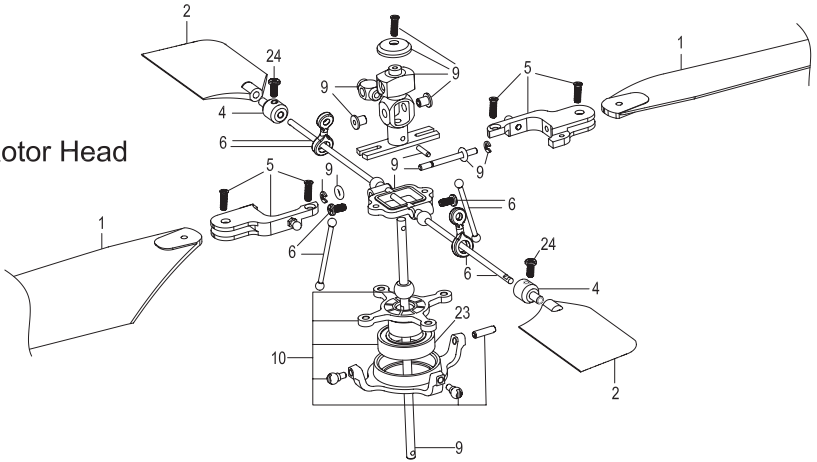

## Main Frame

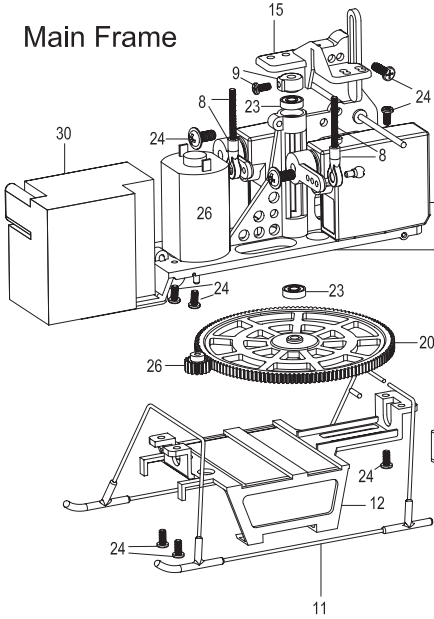

## Tail Rotor

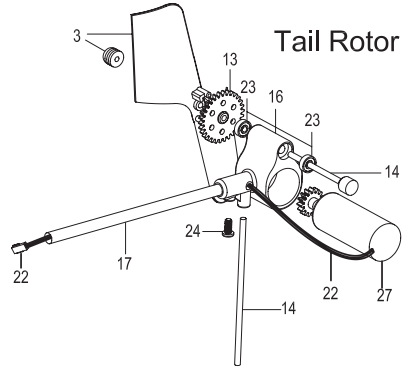

## Canopy

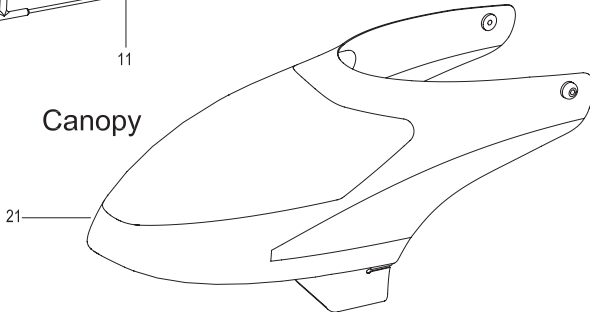

## ***Heli-Max Novus FP Parts List***

1. HMXE8325 . . . . Main Rotor Blades Novus FP
2. HMXE8545 . . . . Flybar Paddles Novus FP
3. HMXE8430 . . . . Tail Rotor Blade Novus FP
4. HMXE8546 . . . . Flybar Weight/ Paddle Mount Novus FP
5. HMXE8547 . . . . CNC Main Blade Grips Novus FP
6. HMXE8548 . . . . Flybar Assembly w/ Linkage Novus FP
8. HMXE8549 . . . . Servo Linkage Set Novus FP
9. HMXE8550 . . . . CNC Rotor Head w/Mainshaft Assembly Novus FP
10. HMXE8551 . . . . CNC Swashplate Assembly Novus FP
11. HMXE7945 . . . . Landing Gear Novus FP
12. HMXE7946 . . . . Battery Tray Novus FP
13. HMXE8431 . . . . Tail Rotor Gear Novus FP
14. HMXE8432 . . . . CF Tail Skid w/Tail Rotor Drive Shaft Novus FP
15. HMXE8433 . . . . Servo Frame Mount Novus FP
16. HMXE8434 . . . . Tail Motor Mount Novus FP
17. HMXE8435 . . . . CF Tail Boom Novus FP
19. HMXE7947 . . . . Main Frame Novus FP
20. HMXE8033 . . . . Main Gear Novus FP
21. HMXE7395 . . . . Printed Canopy Novus FP
22. HMXE9537 . . . . Tail Motor Wire Novus FP
23. HMXE8830 . . . . Bearing Set Novus FP
24. HMXE7330 . . . . Complete Screw Set Novus FP
25. HMXM2023 . . . . Digital 3g Nano Servos (2) Novus FP
26. HMXG8009 . . . . Main Drive Motor Novus FP
27. HMXG8010 . . . . Tail Rotor Motor w/Pinion Novus FP
28. GPMP0408 . . . . 1S LiPo 400 mAh Battery Novus CX/FP
29. HMXP2019 . . . . 1S LiPo Charger Novus CX/FP
30. HMXM2022 . . . . E-Board Novus FP
31. HMXJ2021 . . . . 4Ch 2.4 GHz Transmitter Novus CX/ FP

## ***Novus FP Option Parts***

- HMXE7955 . . . . Main Frame Brushless Upgrade Novus FP
- HMXG8013 . . . . Brushless Motor Novus FP
- HMXM3005 . . . . Brushless ESC Novus FP
- HMXM8014 . . . . Tail Motor Upgrade For Brushless Kit Novus FP
- HMXM3006 . . . . RX2400BL Brushless Version Novus FP
- HMXG8016 . . . . Brushless Upgrade Kit RX,ESC,Tail Motor, BL Motor Novus FP
- GPMM3150 . . . . Charge Lead Banana to HMX Micro Plug

# Optional products available for the Novus CX

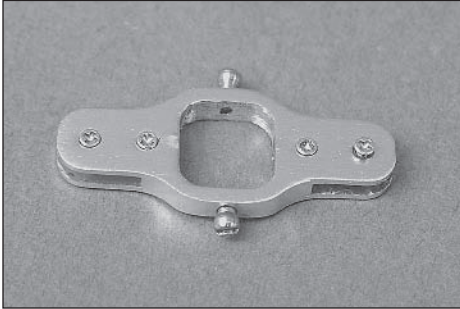

**CNC Main Blade Grips Upper & Lower**  
HMXE7468

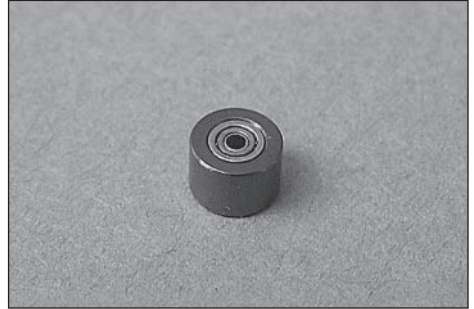

**Outer Shaft w CNC Retainer Collar**  
HMXE7469

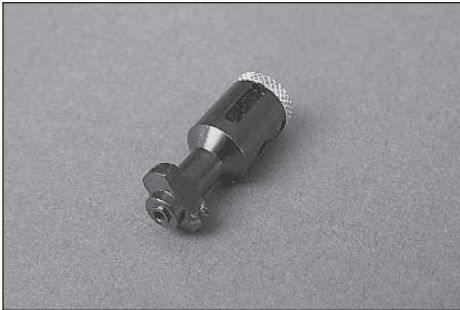

**CNC Head Block W Inner Rotor Shaft**  
HMXE7470

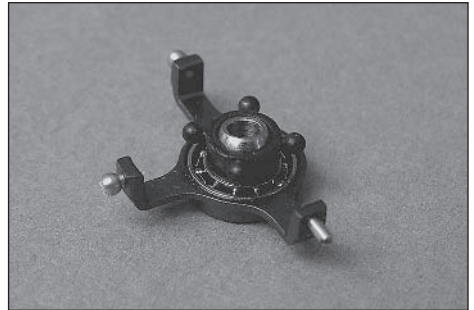

**CNC Swashplate Assembly**  
HMXE7471



# Optional products available for the Novus FP

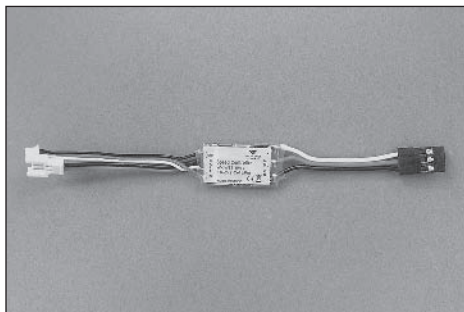

**Brushless ESC**  
HMXM3005

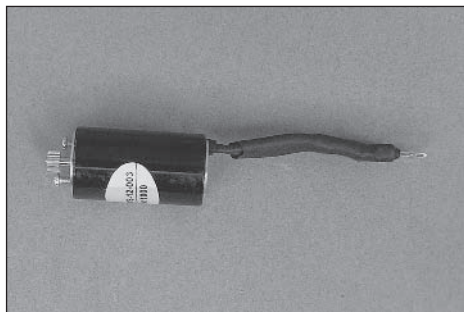

**Brushless Motor**  
HMXXG8013

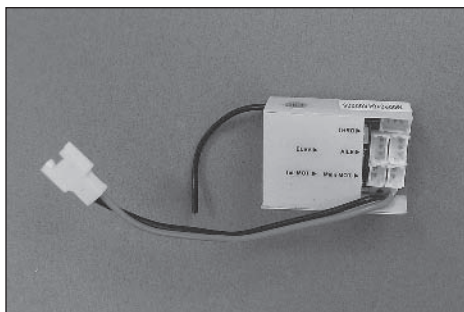

**RX2400BL Brushless Version**  
HMXM3006

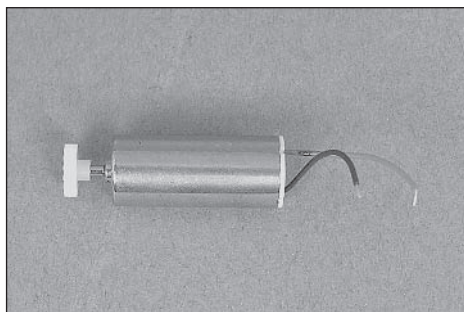

**Tail Motor Upgrade For Brushless Kit**  
HMXXM8014

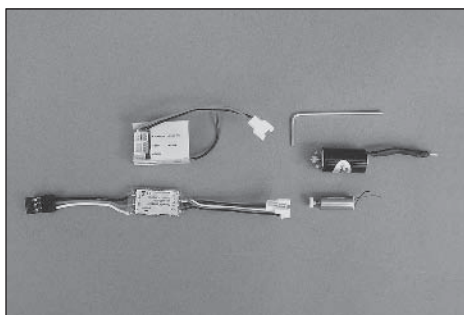

**Brushless Upgrade Kit RX,  
ESC, Tail Motor, BL Motor**  
HMXXG8016

## Other fine products



### **Heli-Max Axe™ EZ EP Mini RTF**

HMXE05\*\*



### **Heli-Max Novus CX**

HMXE0803



### **Heli-Max AXE CPv3 Micro RTF**

HMXE07\*\*



### **Heli-Max Axe CX Micro Coaxial RTF**

HMXE09\*\*

available from **Heli-Max™**

**Heli-Max  
Kinetic™ 50 ARF**

HMXE0250



**Heli-Max  
Novus FP**

HMXE0802



**Heli-Max AXE  
400 3D RTF**

HMXE0800



**Heli-Max AXE  
400 3D RxR**

HMXE0801



