

THE ARMSAFE® SYSTEM

PATENT PENDING

Table of Contents

Introduction	page 1
Safety	page 2
Specifications	page 2
Installation	page 2-3
User Guide	page 4

Introduction

Schumacher Products LLC has developed this *patent pending* ArmSafe® System. This system was developed to have all the features RC modelers want:

1. High Current Rating
2. Small Size
3. Proven Connector Reliability
4. Easy to Install
5. Easy to Use.

When this system is correctly installed and correctly used it can help improve the safety of electric RC models. The system provides the user with more control of WHEN they energize and WHEN they de-energize their RC models. The ArmSafe® Arming System uses genuine Deans® Ultra Plugs® Pat# 5,533,915.



The ArmSafe® System comes in the following configurations. Note that the Kits include everything needed for one complete arming system: AS1-B Base, AS1-P Plug, 18" of High Flex Silicone Wire, and shrink tubing.

<u>Part No.</u>	<u>Description</u>
AS1-B	ArmSafe® Arming Base
AS1-P	ArmSafe® Arming Plug
AS1-K14	ArmSafe® Arming Kit 14AWG wire.
AS1-K12	ArmSafe® Arming Kit 12AWG wire.
AS1-K10	ArmSafe® Arming Kit 10AWG wire.



Safety

It is CRITICAL to fully understand that no product can guarantee your safety with RC models. ArmSafe® is just a tool to help modelers reduce, not eliminate, the risk of propeller strikes when working with electric RC models. ArmSafe® ONLY helps modeler have better control of WHEN they energize and WHEN they de-energize their models. The arming plug should ONLY be inserted into a properly installed ArmSafe® base, nothing else!!

ArmSafe® will NOT keep you safe if you decide to energize your model before ALL is safe. For example if you energize your model when it is sitting on a bench UNSECURED, or if you energize your model when people or personal property are in dangers way. The person in charge of the RC model must handle and operate the model carefully at all times. The person in charge of the RC model is 100% responsible for the safety of themselves and other people, as well as responsible for any personal property. The person in charge of the RC model must use their judgment and safe operating practices to ensure the safety of themselves and others.

Specifications

Schumacher Products LLC is providing these amperage limits as a guide to help size ArmSafe® for RC models. But this is just a guide, you must test all installations at FULL load conditions to make sure that the wire and connectors do not get hot. These amperage guides are rated with 10mph x 80degF air flow for eight minutes, with burst ratings for 5 seconds provided the average current (including the bursts) does not exceed the Max Continuous amperage rating.

Wire AWG	Max Continuous	Max Burst
14	50Amps	75Amps
12	80Amps	120Amps
10	100Amps	150Amps

Many factors will affect the amperage carrying capacity of wire, connectors, and wire harness assemblies such as; wire lengths, air temperature, amount of air movement, quality of the solder joints, wire quality, connector quality, and how long the current flows through the wire.

Installation

1. Open your ArmSafe® Kit, it contains:
1 Female Ultra Plug®, 1 Black Base, 1 Aluminum Nut-Ring, 3 Pan Head Screws 2-56 x 1/2, 2 Sharp Point 4-40 x 3/16 Set Screws, 18” of High Flex Silicone Wire, Shrink Tubing, and 1 Arming Plug.
2. Select the location to install the ArmSafe® Base in your RC model. The ideal location would be close to the battery & ESC to reduce the wiring length. If this is not possible, be sure to use large enough wire to carry the amperage without having the wires get hot during operation. The location should also be chosen for safe and easy access to the model when it is on the ground and ready to operate. This will allow the user to safely connect and disconnect the arming plug from behind the propeller.
3. Use the Nut Ring as a template for marking the hole location, and trace out the inner diameter and the three screw locations, as shown to the right. Cut out the circle and the three holes and test fit the base.

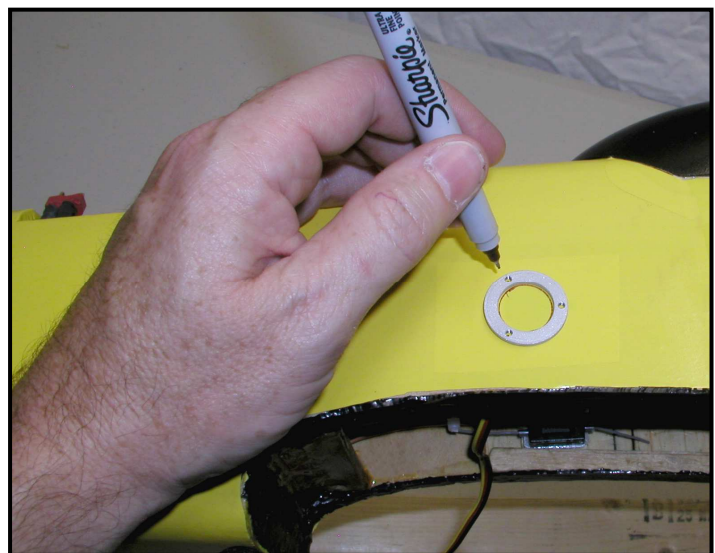

- The next step is to solder the female Deans® Ultra Plug® into the red wire that that goes from the ESC to the battery connector, as per the wiring drawing below-right. Use the wire in the kit to extend the length of the red wire as needed to make the female plug reach the cutout location, as shown below-left.

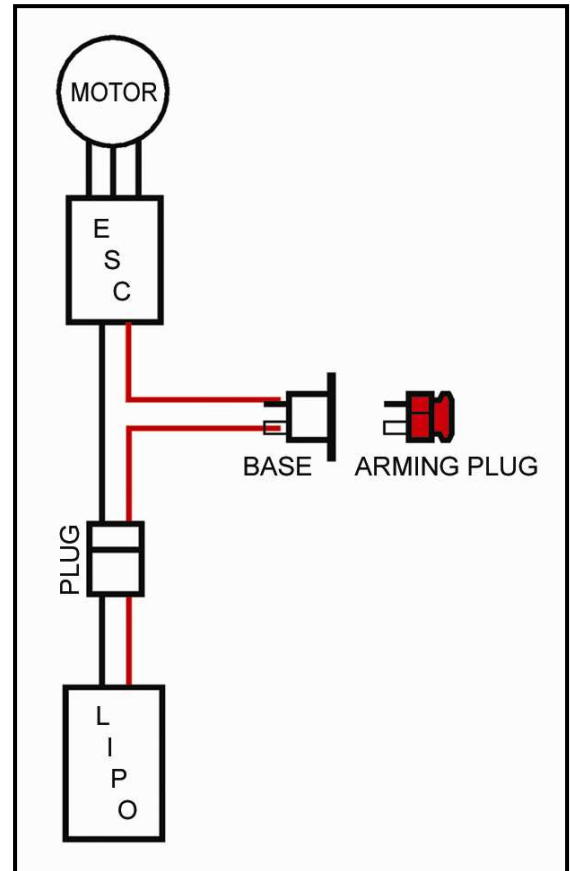
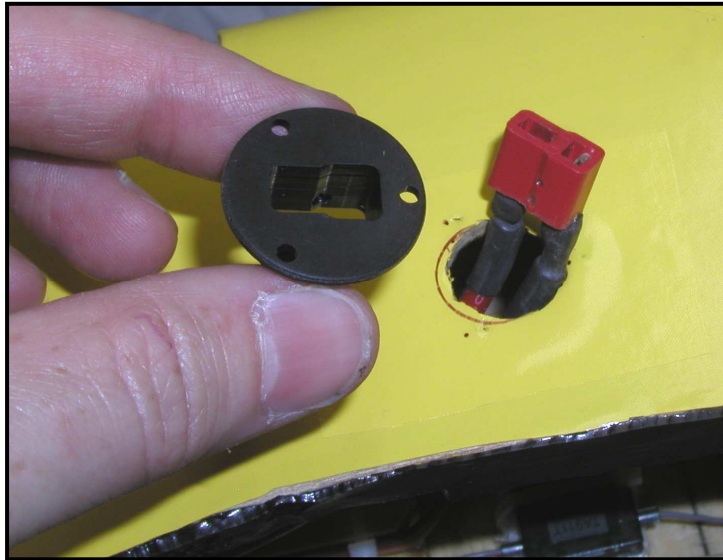

- The three 2-56 x 1/2 long pan head screws are thread forming screws. Use these screws to form the threads in the 3 small holes in the Aluminum Nut-Washer. This is done by installing the screws into the holes and then removing the screws.
- Put the Nut-Ring over the female plug and onto the wires. Feed the female plug through the hole in the fuselage, with the Nut-Ring on the inside of the fuselage.
- Slide the Black Base over the female plug, and then use the two set screws to secure the female plug into the Black Base. **DO NOT over tighten the set screws, just tighten them lightly until the female connector is secure.** The two set screws are sharp pointed and they hold the plug great. After lightly tightening the set screws, test the holding power of the set screws by pushing hard on the female plug to insure that the plug is secure.
- Insert the Black Base into the hole in the fuselage. Use the three 2-56 x 1/2 long pan head screws to secure the Black Base to the Nut-Ring, as shown to the right.
- This completes the installation.



User Guide for ArmSafe®

Below is a user guide for the ArmSafe® system. This is just a guide; it is NOT a 100% guaranteed safe operating procedure. RC models are dangerous by their very nature, and it is the responsibility of the person in charge of the RC model to insure the safety of themselves, other people, and any personal property.

1. Make sure you are FULLY knowledgeable with general RC safety; this is a MUST before proceeding.
2. Perform a preflight check on the model to insure all components are installed properly, and the model is safe to operate. Perform a range check on the model as per your Tx/Rx manufacture's recommendations. If you are not qualified to do these preflight checks; DO NOT proceed!!! You NEED to get the help and training of an experienced RC modeler.
3. Make SURE the ArmSafe® Arming Plug (and the LiPo battery) is removed from the model.
4. SECURE the RC model so that it can NOT move, even under full throttle.
5. Turn ON your transmitter, and select the correct model. AGAIN, make SURE the ArmSafe® Arming Plug is removed from the model. ALWAYS handle the model from a safe location behind the propeller, and handle the model as if it were always energized and could start at any moment.
6. Make sure EVERYONE is at a safe location behind your (or your club's) safe flight line, and install the LiPo battery into the model. Even with the Arming Plug removed, ALWAYS handle the RC model from a safe location behind the propeller, and handle the model as if it were always energized and could start at any moment. Move the model to the safe flight line location.
7. SECURE the model so that it can NOT move, even under full throttle. When ALL is safe and you are prepared (and qualified) to operate the RC model, install the ArmSafe® plug into the ArmeSafe® base in the model, this will energize the model. Test all of the control surfaces and test the throttle to insure everything is working correctly.



8. Operate the RC model in a safe manor, and always be aware that you are 100% responsible for the safety of yourself, other people, and any personal property.
9. After landing the RC model remove the Arming Plug as soon as possible to de-energize the model. ALWAYS handle the RC model from a safe location behind the propeller.
10. Then remove the LiPo battery as soon as possible, and ALWAYS handling the RC model from a safe location behind the propeller.